

TEST SOCKETS & ADAPTERS

01

Swiss Manufacturing Plant



This building served for the production of Swiss precision watches for a period of 70 years.

In 1984 the facility was purchased, completely renovated and high technology fully automated production equipment was installed for the production of precision interconnection products.

In 1992 the trademark

E-tec

was registered to cover the complete interconnect product range.

As of 1993 a world-wide sales & distribution network was established to offer fast and efficient service regardless of location.

In addition to the interconnection products E-tec also supplies high quality screw machine parts as well as customized injection moulded and machined products. Our innovative approach to new product development allows us to offer the service, quality and competitive prices our customers demand. Whatever your requirement, be it high volume commodity product or low quantity custom special, **E-tec**, the **“Swiss Connection”** will endeavour to satisfy your requirements.

For any further details please contact E-tec or your closest sales office.

INDEX

[click on page number](#)

Part-Number	Type	Page
	About E-tec Test Sockets & Adapters	A
	Available Retention Frames	B
	Adapter & Converter Solutions	B
	Socket & Retention System Selector Guides	C
	General Product Information	D
ABG xxx-Exxx-xx X 55 xx	BGA Solder Adapter	11
BPC xxxx-xx xx-xx XX xx	BGA Socket ClamShell “Professional”	7 & 8
BPE xxxx-xx xx-xx XX xx	BGA Socket ClamShell “Economy”	6 & 8
BPF xxxx-xx xx-xx XX xx	BGA Socket FastLock	1 & 8
BPQ xxxx-xx xx-xx XX xx	BGA Socket QuickLock	4 & 8
BPW xxxx-xx xx-xx XX xx	BGA Socket TwistLock	2 & 8
BPZ xxxx-xx xx-xx XX xx	BGA Socket LeverLock	5 & 8
BUC xxxx-xx xx-xx XX xx	BGA Socket ClamShell “Professional”	7 & 8
BUE xxxx-xx xx-xx XX xx	BGA Socket ClamShell “Economy”	6 & 8
BUF xxxx-xx xx-xx XX xx	BGA Socket FastLock	1 & 8
BUQ xxxx-xx xx-xx XX xx	BGA Socket QuickLock	4 & 8
BUW xxxx-xx xx-xx XX xx	BGA Socket TwistLock	2 & 8
BUZ xxxx-xx xx-xx XX xx	BGA Socket LeverLock	5 & 8
CPC xxxx-xx xx-xx XX xx	Column Grid Socket ClamShell “Professional”	7 & 8
CPE xxxx-xx xx-xx XX xx	Column Grid Socket ClamShell “Economy”	6 & 8
CPF xxxx-xx xx-xx XX xx	Column Grid Socket FastLock	1 & 8
CPQ xxxx-xx xx-xx XX xx	Column Grid Socket QuickLock	4 & 8
CPW xxxx-xx xx-xx XX xx	Column Grid Socket TwistLock	2 & 8
CPZ xxxx-xx xx-xx XX xx	Column Grid Socket LeverLock	5 & 8
EBE xxxx-xx xx-xx XX xx	BGA Socket Elastomer Interposer Type ClamShell “Economy”	9
EBF xxxx-xx xx-xx XX xx	BGA Socket Elastomer Interposer Type FastLock	9
EBQ xxxx-xx xx-xx XX xx	BGA Socket Elastomer Interposer Type QuickLock	9
EBW xxxx-xx xx-xx XX xx	BGA Socket Elastomer Interposer Type TwistLock	9
EGF xxxx-xx xx-xx XX xx	GullWing Chip Socket Elastomer Interposer Type FastLock	9
EGQ xxxx-xx xx-xx XX xx	GullWing Chip Socket Elastomer Interposer Type QuickLock	9
EGW xxxx-xx xx-xx XX xx	GullWing Chip Socket Elastomer Interposer TwistLock	9
ELE xxxx-xx xx-xx XX xx	LGA/QFN Socket Elastomer Interposer Type ClamShell “Economy”	9
ELF xxxx-xx xx-xx XX xx	LGA/QFN Socket Elastomer Interposer Type FastLock	9
ELQ xxxx-xx xx-xx XX xx	LGA/QFN Socket Elastomer Interposer Type QuickLock	9
ELW xxxx-xx xx-xx XX xx	LGA/QFN Socket Elastomer Interposer Type TwistLock	9
FCT xxx-Xxxx-xx	ZIF Test sockets for Flex Cables	16
LPC xxxx-xx xx-xx XX xx	Land Grid Socket ClamShell “Professional”	7 & 8
LPE xxxx-xx xx-xx XX xx	Land Grid Socket ClamShell “Economy”	6 & 8
LPF xxxx-xx xx-xx XX xx	Land Grid Socket FastLock	1 & 8
LPQ xxxx-xx xx-xx XX xx	Land Grid Socket QuickLock	4 & 8
LPW xxxx-xx xx-xx XX xx	Land Grid Socket TwistLock	2 & 8
LPZ xxxx-xx xx-xx XX xx	Land Grid Socket LeverLock	5 & 8
LQE xxxx-xx xx-xx XX xx	QFN/MLF/MLP Socket ClamShell “Economy”	13
LQF xxxx-xx xx-xx XX xx	QFN/MLF/MLP Socket FastLock	13
LQQ xxxx-xx xx-xx XX xx	QFN/MLF/MLP Socket QuickLock	13
LQW xxxx-xx xx-xx XX xx	QFN/MLF/MLP Socket TwistLock	13
MGS xxxx-Exxx-xx X 95 xx	MiniGrid Socket	12
MGS xxxx-SB01-xx X 95 xx	MiniGrid SMT Solder Ball Adapter	10
QFC xxxx-xx xx-xx XX xx	GullWing Chip Socket ClamShell	14
QFF xxxx-xx xx-xx XX xx	GullWing Chip Socket FastLock	14
QFQ xxxx-xx xx-xx XX xx	GullWing Chip Socket QuickLock	14
QFW xxxx-xx xx-xx XX xx	GullWing Chip Socket ScrewLock	14
TOL-7CN-TORQUE	Torque Limiting Screwdriver Kit	15

E-tec test sockets are custom made high temperature sockets to test IC packages on a PCB (BGA, LGA, CGA, QFN, GullWing type, etc.).

Generally used for prototyping, pre-production and test & burn-in, the E-tec test sockets allow the customer to insert an IC package into the socket, test it in its original condition and remove it again for final soldering to the PCB after all tests have been completed. The sockets are easily adaptable to customer requirements.

Main questions on how to choose a socket

- **Which IC package needs to be tested?**
 - **E-tec offers socket solutions for any chip types**
The mechanical dimensions of the IC package are critical for defining the appropriate socket, thus a dimensional drawing always needs to be submitted.
- **Which contact style should be chosen?**
 - **Generally depends on contact durability, operating temperatures and/or frequency.**
Three main contact styles are available:
 - E-tec patented Probe pins (standard) up to 3.4 GHz
 - High Speed Probe pins (up to 30 GHz)
 - Elastomer interposers (up to 30 GHz)
- **How to connect the socket to the PCB?**
 - SMT (standard or raised)
 - Thru-hole
 - Solderless compression (probe pin or elastomer interposer)
- **Which socket retainer style is needed?**
 - Various factors will influence the choice of the retainer solution chosen, such as:
 - How many times will the socket be opened each day?
 - Cost of socket?
 - Is there any space limitation for the socket ?
 - Access required to the die of chip / heat dissipation (open top?)

Options for attaching the socket to the PCB

SMT soldering type
(Low profile, short signal path)

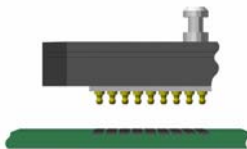

Raised SMT type
(lifts socket above close-by components)

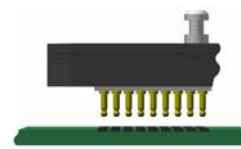

Thru hole soldering type
(Generally for test & burn-in applications)

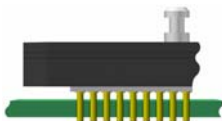

Solderless Compression type
(short signal path, avoids soldering process)

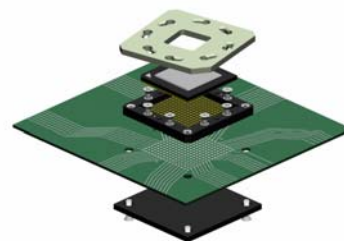

Available Retention frames

FastLock

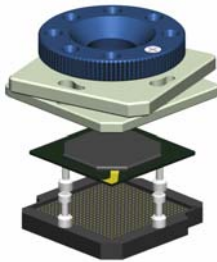

with lever
for high pincount

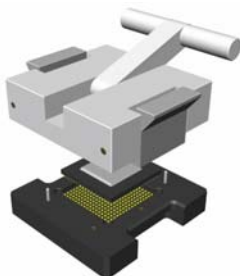

TwistLock

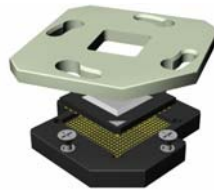

QuickLock

without lever
for low pincount

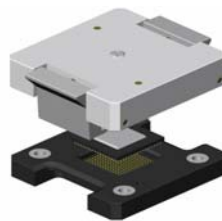

LeverLock

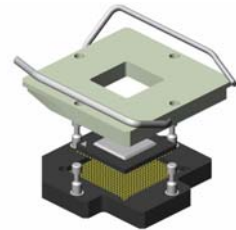

open top
(on request)

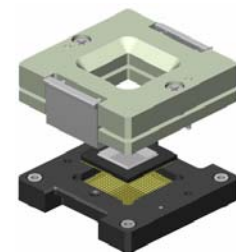

ClamShell

Economy
Open top

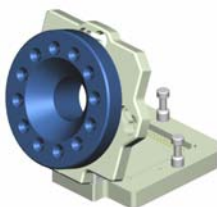

Professional
closed top

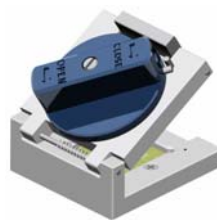

Professional
open top (on request)

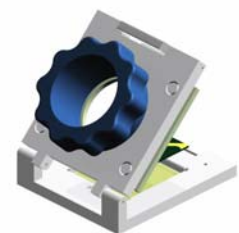

SMT Adapter solution for plugging a test socket

- solderball or solid pin surface mount sockets
- easy to solder (especially high pincount)
- easy plugging of test socket after soldering

Step 1: solder mini-grid socket to PCB
Step 2: plug test socket into mini-grid socket

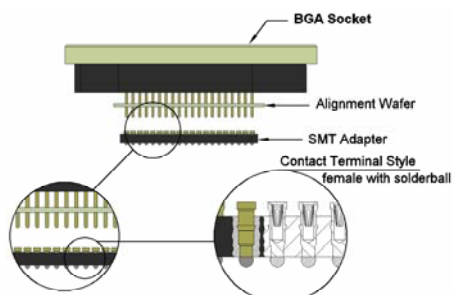

Converter Adapter solution

- generally for high volume requirements
- mini-grid sockets available with solder balls or regular solid pins

Step 1: mini-grid socket soldered to PCB
Step 2: chip soldered to adapter board (converting BGA to PGA)
Step 3: Plug adapter board into mini-grid socket

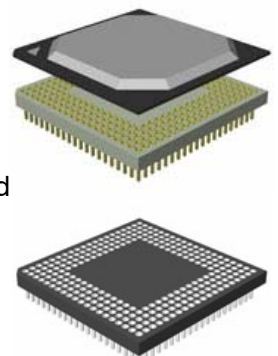

The below Socket & Retention System Selector Guides will help you to make the right choice.

The options indicated refer to standard options. If you should not find what you need or if your specs should vary from the below chart, please contact your closest E-tec office, since we will most likely be able to offer a customized solution also.

Socket Selector Guide

Socket style	Lowest Pitch	Contact interface			Available Temperature range	Chip types						
		Regular Probe pin (up to 3.4 GHz)	High speed (up to 30 GHz)	Replaceable contacts		BGA/CSP	CGA	LGA	QFN	LCC	Gullwing (QFP, TSOP, SSOP, etc)	Others
Surface Mount	0.50mm	Yes	No	No	-55°C to +125°C	Yes	Yes	Yes	Yes	Yes	Yes	on request
Raised Surface Mount	0.50mm	Yes	No	No	-55°C to +125°C	Yes	Yes	Yes	Yes	Yes	Yes	on request
Thru-hole	0.50mm	Yes	No	No	-55°C to +125°C	Yes	Yes	Yes	Yes	Yes	Yes	on request
Solderless Probe pin	0.40mm	Yes	Yes	only high speed probes	-55°C to +125°C	Yes	Yes	Yes	Yes	Yes	Yes	on request
Solderless Elastomer	0.30mm	n/a	Yes	Yes	-35°C to +125°C	Yes	No	Yes	Yes	No	Yes	on request

Retention System Selector Guide

Retention frame style	Socket Cost	Open top	Open/close cycles	Socket size	Socket height above board	Tools required to open/close	Torque tool option	available with integrated heatsink	Recommended for SMT sockets	Accepted chip heights	Accepted max. chip height variations from min to max	Accepted min/max chip size	Available for elastomer sockets	Available for "gullwing chip" sockets	Available for gullwing chips with "tie bar" attached to legs
TwistLock / ScrewLock	Low	Yes	1000	smallest	lowest	Yes	Yes	Yes	Yes	no limit	no limit	min 4x4mm max no limit	Yes	Yes	Yes
FastLock	Low	Yes	10000	small	medium	No	Yes	Yes	Yes, with locating pegs	no limit	2.5mm	min 4x4mm max 52x52mm	Yes	Yes	Yes
Economy ClamShell	Low	Yes	10000	small	medium	No	Yes	Yes	Yes, with locating pegs	no limit	2.5mm	min 7x7mm max 50x50mm	Yes	No	No
LeverLock	Medium	Yes	1000	small	low	No	No	No	Yes, with locating pegs	no limit	0.40mm	min 15x15mm max 40x40mm	Yes	No	No
QuickLock	Medium to High	on request	10000	medium	high	No	No	No	Yes	min 0.5mm max 3.5mm	3.0mm	min 4x4mm max 36x36mm	Yes	Yes	No
Professional ClamShell	High	on request	10000	largest	high	No	No	No	Yes, with locating pegs	min 0.5mm max 4.0mm	3.5mm	min 7x7mm max 40x40mm	Yes	Yes	No
Adapter solution (mini-grid socket & pluggable Test socket)	Depends on retention system	Depends on retention system	Depends on retention system	small adapter base	high	Depends on retention system	Depends on retention system	Depends on retention system	Yes with small size locking systems	Depends on retention system	Depends on retention system	Depends on retention system	Yes	Yes	Yes

General Socket Recommendations

TwistLock Test Socket

1. Use the E-tec torque tool **TOL-7CN-TORQUE** with appropriate torque setting for TwistLock sockets. Generally 7cNm up to 800 pins and 7cNm to 10cNm for higher pin counts.
2. Close the screws of the retainer with light tightening first and then fully tighten the screws one after each other. For sockets with 4 or 8 screws tighten the screws “cross wise” to apply equal forces.

SMT Test Socket

1. Use solder paste without silver or less than 0.5% silver content.
2. Solder profile & socket mounting recommendations are available for download from our homepage www.e-tec.com
3. Whenever possible use locating pegs which are tin plated for soldering to the PCB. This avoids the solder joints from being stressed during handling of the socket. Socket life cycle can be heavily reduced if used without locating pegs.
4. For high pin count sockets, it's preferable to solder a light weight mini-grid adapter to the PCB first and then plug the test socket into that adapter.
5. Choose the raised SMT socket for lifting the socket above close-by components. Special clearances in the socket body can also be offered on request.

Solderless Test Socket

1. Use gold plated PCB pads (hard gold if possible).
2. PCB pads must be flush or higher than the solder mask for reliable interconnection with the socket.
3. Clearance for close-by components or components underneath the PCB can be offered on request.

Test Socket with Mini-Grid SMT Adapter

When inserting the test socket into the mini-grid adapter, make sure that the pin alignment plate has been positioned at the tip of the test socket pins. During insertion, this plate will then be pressed backwards and remain seated in-between the socket and the mini-grid adapter. This pin alignment board ensures correct alignment of the test socket pins onto the pins of the mini-grid adapter and thus reduces the risk of damaging the test socket pins during insertion. If the adapter socket has been removed from the mini-grid socket, then this pin alignment board needs to be pushed back to the tip of the test socket pins prior to reinserting the test socket into the mini-grid adapter.

E-tec Patented Probe Pin Designs

BGA ball grid array contact design
(patented)
standard size solderballs

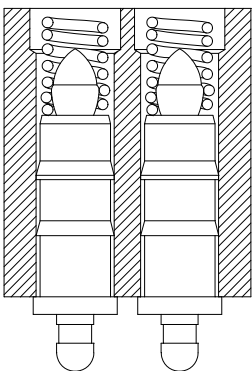

BGA ball grid array contact design
(patented)
small size solderballs

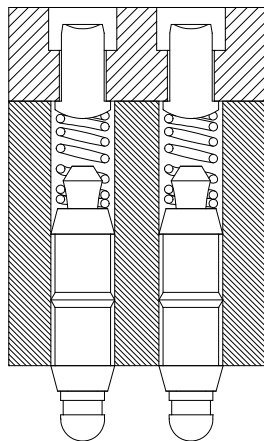

LGA land grid array contact design
(patented)

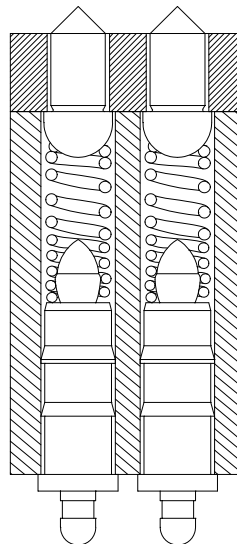

CGA Column grid contact design
(patented)

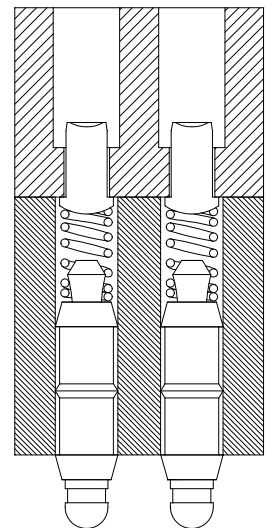

Ball / Land Grid Array Sockets

FastLock Type



E-tec is now the leading BGA socket manufacturer.

EP patents 0829188, 0897655 US patents 6190181, 6249440 Patented in other countries.

FastLock sockets are available for any chip size and grid pattern. The SMT socket is simply placed and reflowed onto the PCB in the same way as the chip and occupies only a small amount of additional board space. The solderless sockets are mounted with 2 or 4 mounting pegs to the PCB depending on the chip size. The FastLock retainer uses a thumbscrew which does not require any tools for opening/closing of the socket. Torque tools or adjustment of pressdown force are available with this locking system also.

We aim to solve your requirements – your custom sets our standards!

Please note, we will always request the chip data to ensure we offer a compatible socket.

FastLock Type

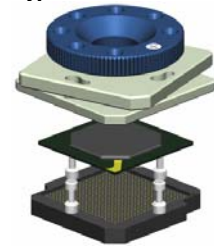

SMT style

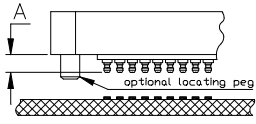

PCB Pad Layout

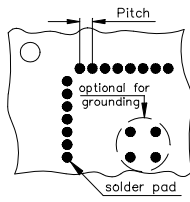

- Ø 0,60mm/.024" if pitch 1,27mm
- Ø 0,50mm/.020" if pitch 1,00mm
- Ø 0,40mm/.016" if pitch 0,80mm
- Ø 0,35mm/.014" if pitch 0,75mm
- Ø 0,35mm/.014" if pitch 0,65mm
- Ø 0,30mm/.012" if pitch 0,50mm

Soldertail style

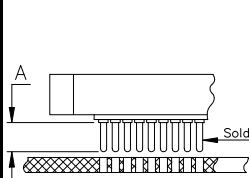

PCB Pad Layout

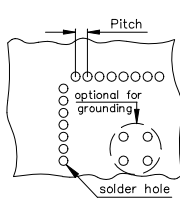

Soldertail dimension:

- Ø 0,42mm/.016" if pitch 1,27mm
- Ø 0,29mm/.011" if pitch 1,00mm
- Ø 0,29mm/.011" if pitch 0,80mm
- Ø 0,27mm/.010" if pitch 0,75mm
- Ø 0,27mm/.010" if pitch 0,65mm
- Ø 0,27mm/.010" if pitch 0,50mm
- Ø 0,17mm/.007" if pitch 0,40mm

PCB solder hole:

- Ø 0,60mm/.024" if pitch 1,27mm
- Ø 0,50mm/.020" if pitch 1,00mm
- Ø 0,40mm/.016" if pitch 0,80mm
- Ø 0,35mm/.014" if pitch 0,75mm
- Ø 0,35mm/.014" if pitch 0,65mm
- Ø 0,35mm/.014" if pitch 0,50mm
- Ø 0,25mm/.010" if pitch 0,40mm

Solderless Compression style

(FastLock Type as example shown)

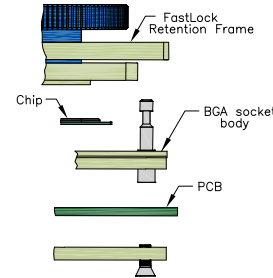

PCB Pad Layout

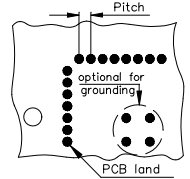

You may request any specific socket dimension from info@e-tec.com

- gold plated pads Ø 0,70mm/.027" if pitch 1,27mm
- gold plated pads Ø 0,60mm/.024" if pitch 1,00mm
- gold plated pads Ø 0,50mm/.020" if pitch 0,80mm
- gold plated pads Ø 0,45mm/.018" if pitch 0,75mm
- gold plated pads Ø 0,40mm/.016" if pitch 0,65mm
- gold plated pads Ø 0,35mm/.012" if pitch 0,50mm
- gold plated pads Ø 0,25mm/.010" if pitch 0,40mm

Solderless Compression Type and other locking systems (on request)

FastLock Type

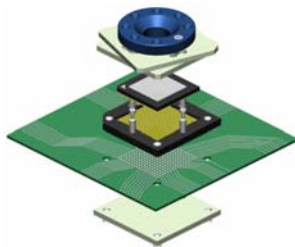

Important Note:

Please check the ball diameters & heights of your chip prior to ordering the standard E-tec BGA (BPC) sockets. Any deviation has to be communicated to E-tec in order to check compatibility with the standard socket design and if necessary to obtain a special order code adapted to your chip dimensions. The standard solderball diameters & heights are the following:

Pitch	ball diameters min/max	ball height min/max
0,50mm	0,25mm 0,35mm	0,20mm 0,30mm
0,65mm	0,25mm 0,45mm	0,20mm 0,30mm
0,75mm	0,25mm 0,45mm	0,20mm 0,40mm
0,80mm	0,40mm 0,55mm	0,25mm 0,45mm
1,00mm	0,50mm 0,70mm	0,30mm 0,50mm
1,27mm & higher	0,60mm 1,00mm	0,50mm 1,00mm

If the minimum ball diameter of a given chip falls below the above indications, then a BUF socket will generally be proposed.

Specifications

Mechanical data

- Contact life 10.000 cycles min.
- Retention system life 10.000 cycles min.
- Solderability as per IEC 60068-2-58
- Individual contact force 40 grams max.

Material

- Insulator (RoHS compliant) High temp plastic or epoxy FR4
- Terminal (RoHS compliant) Brass
- Contact (RoHS compliant) BeCu

Electrical data

- Contact resistance < 100 mΩ
- Current rating 500 mA max.
- Insulation resistance at 500V DC 100 MΩ if 0.50 to 0.80mm pitch
- 500 MΩ 1.00mm pitch upwards
- Breakdown voltage at 60 Hz 500V min.
- Capacitance < 1 pF
- Inductance < 2 nH

Operating temperature

- 55°C to +125°C ; 260°C for 60 sec.

Recommendations:

Solder paste – Please use a solder paste w/o any silver!

E-tec solderless sockets are adapted to a standard PCB thickness of 1.60mm. For a different PCB thickness, please inform E-tec first!

SMT FastLock sockets are recommended to be ordered with locating pegs for soldering to the PCB, to avoid the solderjoints from being stressed due to the torque forces applied with this locking system. If used without locating pegs, the life cycle of the socket may be heavily reduced.

For high pincount SMT sockets, E-tec recommends the use of a pluggable thru-hole socket mounted into a MiniGrid Adapter (see also pages 10, 11 & 12 for more details).

How to order

X X F x x x x - x x x x - x x x x x x L ← optional for locating pegs

Device Type

- B = Ball Grid
- L = Land Grid
- C = Column Grid

Socket Type

- P = socket for LGA, CGA and BGA chips with standard diameter solderballs (see dimensions in table above)
- U = socket for small diameter solderballs

Pitch

- 04 = 0,40mm
- 05 = 0,50mm
- 06 = 0,65mm
- 07 = 0,75mm
- 08 = 0,80mm
- 10 = 1,00mm
- 12 = 1,27mm
- 15 = 1,50mm
- others on request

Grid Code

Config Code

will be given by the factory after receipt of the chip datasheet

Plating

- 95 = tin/gold (tin leadfree)
- 55 = gold only for Compression Type

Nbr of contacts

depends on ballcount of chip

Contact Type

- 30 = standard SMT... („A“ = 1,20mm if 1,27mm pitch; 0,80mm if 1,00mm pitch, 0,60 if 0,80mm pitch; 0,40mm if <0.80mm pitch)
- 29 = raised SMT... („A“ = 5,00mm if 1,27mm pitch; 3,20mm if 1,00mm pitch; 2,80mm if 0,80mm pitch, 2,30mm if <0.80mm pitch)
- 28 = special raised SMT - only for 1.00 & 0.80mm pitch... („A“ = 4,50mm)
- 70 = standard solder tail... („A“ = 3,30 if 1,27mm pitch, 2,80 if 1,00mm or 0,80mm pitch, 2,30mm if <0.80mm pitch)
- 90 & 91 = compression type (see page 8 for more details)

Ball / Land Grid Array Sockets TwistLock Type



E-tec is now the leading BGA socket manufacturer.

EP patents 0829188, 0897655 US patents 6190181, 6249440 Patented in other countries.

TwistLock sockets are generally chosen when relatively low insertion / extraction cycles are required and when the cost of the socket is a predominant factor. The TwistLock socket extends by around 6.00mm beyond the outer ball row and special clearances can be offered on request.

We aim to solve your requirements - many different terminals and configurations are available.
Your custom sets our standards!

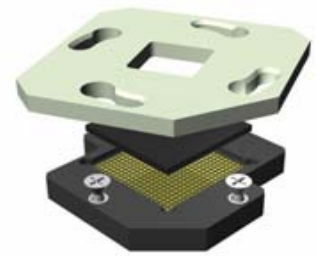

Please note, we will always request the chip data to ensure we offer a compatible socket.

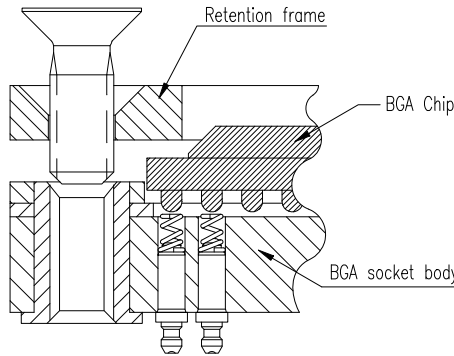
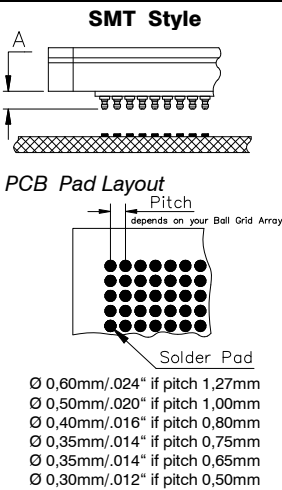

You may request any specific socket dimension from info@e-tec.com

For top view socket dimension pls. ref. to separate catalog page

Important Note:

Please check the ball diameters & heights of your chip prior to ordering the standard E-tec BGA (BPW) sockets. Any deviation has to be communicated to E-tec in order to check compatibility with the standard socket design and if necessary to obtain a special order code adapted to your chip dimensions.

The standard solderball diameters & heights are the following:

Pitch	ball diameters min/max	ball height min/max
0.50mm	0.25mm / 0.35mm	0.20mm / 0.30mm
0.65mm	0.25mm / 0.45mm	0.20mm / 0.30mm
0.75mm	0.25mm / 0.45mm	0.20mm / 0.40mm
0.80mm	0.40mm / 0.55mm	0.25mm / 0.45mm
1.00mm	0.50mm / 0.70mm	0.30mm / 0.50mm
1.27mm & higher	0.60mm / 1.00mm	0.50mm / 1.00mm

If the minimum ball diameter of a given chip falls below the above indications, then a BUW socket will generally be proposed.

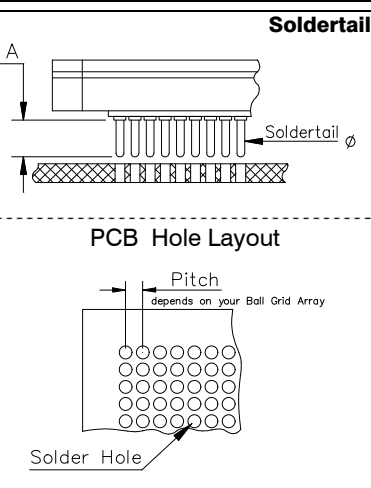

Solderetail:

- Ø 0,42mm/.016" if pitch 1,27mm
- Ø 0,29mm/.011" if pitch 1,00mm
- Ø 0,29mm/.011" if pitch 0,80mm
- Ø 0,27mm/.010" if pitch 0,75mm
- Ø 0,27mm/.010" if pitch 0,65mm
- Ø 0,27mm/.010" if pitch 0,50mm
- Ø 0,17mm/.007" if pitch 0,40mm

PCB solder hole:

- Ø 0,60mm/.024" if pitch 1,27mm
- Ø 0,50mm/.020" if pitch 1,00mm
- Ø 0,40mm/.016" if pitch 0,80mm
- Ø 0,35mm/.014" if pitch 0,75mm
- Ø 0,35mm/.014" if pitch 0,65mm
- Ø 0,35mm/.014" if pitch 0,50mm
- Ø 0,25mm/.010" if pitch 0,40mm

Mechanical data	Specifications
Contact life	10.000 cycles min.
Retention System life	1.000 cycles min.
Solderability	as per IEC 60068-2-58
Individual contact force	40 grams max.
Max. torque for retention screws	up to 800 pins = 7cNm or 10 oz-inch as of 800 pins = 7cNm to 10cNm or 10 oz-inch to 14 oz-inch
Material	
Insulator (RoHS compliant)	High temp plastic or epoxy FR4
Terminal (RoHS compliant)	Brass
Contact (RoHS compliant)	BeCu
Electrical data	
Contact resistance	< 100 mΩ
Current rating	500 mA max.
Insulation resistance at 500V DC	100 MΩ if 0.50mm to 0.80mm pitch 500 MΩ 1.00mm pitch upwards
Breakdown voltage at 60 Hz	500V min.
Capacitance	< 1 pF
Inductance	< 2 nH
Operating temperature	-55°C to +125°C ; 260°C for 60 sec.

Recommendations:

Solder paste – Please use a solder paste w/o any silver!

Solder profile – Please refer to our website www.e-tec.com

E-tec solderless sockets are adapted to a standard PCB thickness of 1.60mm. For a different PCB thickness, please inform E-tec first!

For high pincount SMT sockets, E-tec recommends the use of a pluggable thru-hole socket mounted into a MiniGrid Adapter (see also page 10, 11 & 12 for more details)

For SMT sockets in general, E-tec recommends the use of locating pegs which can be soldered to the PCB for added mechanical strength.

How to order

X X W X X X X - X X X X - X X X X 95 L ← optional for locating pegs

Device Type	Socket Type	Pitch	Grid Code	Config Code	Plating
B = Ball Grid L = Land Grid C = Column Grid	P = socket for LGA, CGA and BGA chips with standard diameter solderballs (see dimensions in table above) U = socket for small diameter solderballs	04 = 0,40mm 05 = 0,50mm 06 = 0,65mm 07 = 0,75mm 08 = 0,80mm 10 = 1,00mm 12 = 1,27mm 15 = 1,50mm others on request	<i>will be given by the factory after receipt of the chip datasheet</i>	<i>will be given by the factory after receipt of the chip datasheet</i>	95 = tin/gold (tin leadfree)

Nbr of contacts

depends on ballcount of chip



Contact Type

- 30** = standard SMT... („A“ = 1,20mm if 1,27mm pitch; 0,80mm if 1,00mm pitch, 0,60 if 0,80mm pitch; 0,40mm if <0,80mm pitch)
- 29** = raised SMT.. („A“ = 5,00mm if 1,27mm pitch; 3,20mm if 1,00mm pitch; 2,80mm if 0,80mm pitch, 2,30mm if <0,80mm pitch)
- 28** = special raised SMT - only for 1.00 & 0.80mm pitch..... („A“ = 4,50mm)
- 70** = standard solder tail..... („A“ = 3.30 if 1.27mm pitch, 2.80 if 1.00mm or 0.80mm pitch, 2,30mm if <0,80mm pitch)
- 90 & 91** = compression type (see page 8 for more details)

Ball / Land Grid Array Sockets

Top View for "TwistLock sockets" (through-hole & SMT style only)

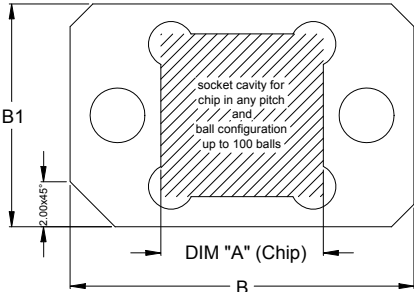
Socket outline for small sized chips up to 100 balls or lands

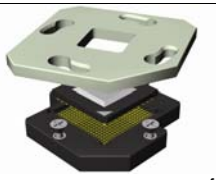
<p>Note: TwistLock sockets up to 100 pins are produced with 2 screws.</p> 	DIM "A" Chip (sq.)	DIM "B" Socket	DIM "B1" Socket	 <p>up to 100 pins</p>
	6.00mm / .236"	14.77mm / .581"	9.87mm / .389"	
	7.00mm / .276"	16.04mm / .631"	11.14mm / .439"	
	8.00mm / .315"	17.31mm / .681"	12.41mm / .489"	
	9.00mm / .354"	18.58mm / .731"	13.68mm / .539"	
	10.00mm / .394"	19.85mm / .781"	14.95mm / .589"	
	11.00mm / .433"	19.85mm / .781"	14.95mm / .589"	
	12.00mm / .472"	21.12mm / .831"	16.22mm / .639"	
	13.00mm / .512"	22.39mm / .881"	17.49mm / .689"	
	14.00mm / .551"	23.66mm / .931"	18.76mm / .739"	
	15.00mm / .591"	24.93mm / .981"	20.03mm / .789"	
	16.00mm / .630"	26.20mm / 1.031"	21.30mm / .839"	
	17.00mm / .669"	26.20mm / 1.031"	21.30mm / .839"	
	18.00mm / .709"	27.47mm / 1.081"	22.57mm / .889"	
	19.00mm / .748"	27.47mm / 1.081"	22.57mm / .889"	
				 <p>as of 101 pins</p>

Socket outline for standard chips as of 101 balls or lands

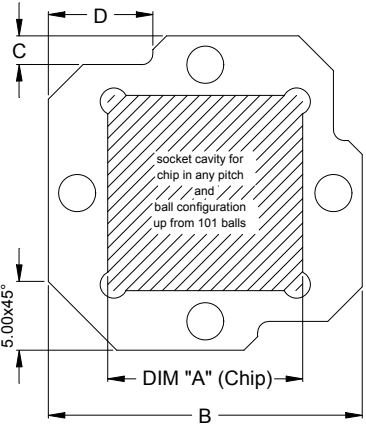
<p>Note: TwistLock sockets from 101 to 600 pins are produced with 4 screws.</p> 	DIM "A" Chip (sq.)	DIM "B" Socket (sq.)	DIM "C" Socket	DIM "D" Socket
	13.00mm / .512"	21.59mm / .850"	2.51mm / .099"	7.62mm / .312"
	14.00mm / .551"	22.86mm / .900"	2.09mm / .082"	7.62mm / .312"
	15.00mm / .591"	24.13mm / .950"	2.81mm / .111"	8.89mm / .350"
	16.00mm / .630"	24.13mm / .950"	2.81mm / .111"	8.89mm / .350"
	17.00mm / .669"	25.40mm / 1.000"	2.84mm / .112"	8.89mm / .350"
	18.00mm / .709"	26.67mm / 1.050"	2.99mm / .118"	8.89mm / .350"
	19.00mm / .748"	27.94mm / 1.100"	2.71mm / .107"	8.91mm / .351"
	20.00mm / .787"	29.21mm / 1.150"	2.70mm / .106"	8.89mm / .350"
	21.00mm / .827"	29.21mm / 1.150"	2.70mm / .106"	8.89mm / .350"
	22.00mm / .866"	30.48mm / 1.200"	2.60mm / .102"	8.89mm / .350"
	23.00mm / .905"	31.75mm / 1.250"	2.88mm / .113"	9.53mm / .375"
	24.00mm / .945"	33.02mm / 1.300"	2.39mm / .094"	8.89mm / .350"
	25.00mm / .984"	33.02mm / 1.300"	2.39mm / .094"	8.89mm / .350"
	26.00mm / 1.024"	34.29mm / 1.350"	2.74mm / .108"	8.89mm / .350"
	27.00mm / 1.063"	35.56mm / 1.400"	2.53mm / .099"	9.53mm / .375"
	28.00mm / 1.102"	36.83mm / 1.450"	2.50mm / .098"	9.53mm / .375"
	29.00mm / 1.142"	38.10mm / 1.500"	2.81mm / .111"	9.53mm / .375"
	30.00mm / 1.181"	38.10mm / 1.500"	2.81mm / .111"	9.53mm / .375"
	31.00mm / 1.220"	39.37mm / 1.550"	2.54mm / .100"	9.53mm / .375"
	32.00mm / 1.260"	40.64mm / 1.600"	2.88mm / .113"	9.53mm / .375"
	32.50mm / 1.279"	40.64mm / 1.600"	2.88mm / .113"	9.53mm / .375"
	33.00mm / 1.299"	41.91mm / 1.650"	2.80mm / .110"	9.53mm / .375"
	34.00mm / 1.339"	43.18mm / 1.700"	2.05mm / .081"	9.53mm / .375"
	34.50mm / 1.358"	43.18mm / 1.700"	2.05mm / .081"	9.53mm / .375"
	35.00mm / 1.378"	43.18mm / 1.700"	2.05mm / .081"	9.53mm / .375"
	36.00mm / 1.358"	44.45mm / 1.750"	3.00mm / .118"	9.53mm / .375"
	37.00mm / 1.457"	45.72mm / 1.800"	2.10mm / .083"	8.26mm / .325"
	37.50mm / 1.476"	45.72mm / 1.800"	2.10mm / .083"	8.26mm / .325"
	38.00mm / 1.496"	46.99mm / 1.850"	3.15mm / .124"	9.53mm / .375"
	39.00mm / 1.535"	48.26mm / 1.900"	2.24mm / .088"	9.53mm / .375"
	40.00mm / 1.575"	48.26mm / 1.900"	2.24mm / .088"	9.53mm / .375"
	41.00mm / 1.641"	49.53mm / 1.950"	3.00mm / .118"	9.53mm / .375"
	42.00mm / 1.653"	50.80mm / 2.000"	2.32mm / .091"	9.53mm / .375"
	42.50mm / 1.673"	50.80mm / 2.000"	2.32mm / .091"	9.53mm / .375"
	43.00mm / 1.693"	52.07mm / 2.050"	2.78mm / .109"	9.53mm / .375"
	44.00mm / 1.732"	52.07mm / 2.050"	2.78mm / .109"	9.53mm / .375"
	45.00mm / 1.772"	53.34mm / 2.100"	2.41mm / .095"	9.53mm / .375"
	46.00mm / 1.811"	54.61mm / 2.150"	3.16mm / .124"	9.53mm / .375"
	47.00mm / 1.850"	55.88mm / 2.200"	3.30mm / .130"	9.53mm / .375"
48.00mm / 1.890"	57.15mm / 2.250"	2.54mm / .100"	9.53mm / .375"	
49.00mm / 1.929"	57.15mm / 2.250"	2.54mm / .100"	9.53mm / .375"	
50.00mm / 1.868"	58.42mm / 2.300"	2.54mm / .100"	9.53mm / .375"	

For Solderless, FastLock, LeverLock, QuickLock, ClamShell & other locking systems or larger size outline dimensions, please contact your E-tec sales office for dimensional drawings.

Ball / Land Grid Array Sockets

QuickLock Type



E-tec is now the leading BGA socket manufacturer.

EP patents 0829188, 0897655 US patents 6190181, 6249440 Patented in other countries.

QuickLock sockets are available for any chip size and grid pattern. They are available in SMT, thru-hole and solderless compression type versions. The SMT socket is simply placed and reflowed onto the PCB in the same way as the chip and it only requires a small amount of additional board space. A lever is added to the QuickLock retention cover if the pincount exceeds 81 pins which allows the required pressdown forces to be applied easily.

We aim to solve your requirements - many different terminals and configurations are available. Your custom sets our standards!

Please note, we will always request the chip data to ensure we offer a compatible socket.

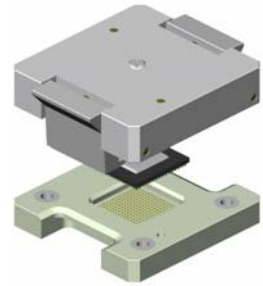

SMT style	Soldertail style	Solderless Compression style
<p>PCB Pad Layout</p> <p>solder pad</p> <p>Ø 0,60mm/.024" if pitch 1,27mm Ø 0,50mm/.020" if pitch 1,00mm Ø 0,40mm/.016" if pitch 0,80mm Ø 0,35mm/.014" if pitch 0,75mm Ø 0,35mm/.014" if pitch 0,65mm Ø 0,30mm/.012" if pitch 0,50mm</p>	<p>PCB Hole Layout</p> <p>solder hole</p> <p>Soldertail dimension:</p> <p>Ø 0,42mm/.016" if pitch 1,27mm Ø 0,29mm/.011" if pitch 1,00mm Ø 0,29mm/.011" if pitch 0,80mm Ø 0,27mm/.010" if pitch 0,75mm Ø 0,27mm/.010" if pitch 0,65mm Ø 0,27mm/.010" if pitch 0,50mm Ø 0,17mm/.007" if pitch 0,40mm</p> <p>PCB solder hole:</p> <p>Ø 0,60mm/.024" if pitch 1,27mm Ø 0,50mm/.020" if pitch 1,00mm Ø 0,40mm/.016" if pitch 0,80mm Ø 0,35mm/.014" if pitch 0,75mm Ø 0,35mm/.014" if pitch 0,65mm Ø 0,35mm/.014" if pitch 0,50mm Ø 0,25mm/.010" if pitch 0,40mm</p>	<p>You may request any specific socket dimension from info@e-tec.com</p> <p>gold plated pads Ø 0,70mm/.027" if pitch 1,27mm gold plated pads Ø 0,60mm/.024" if pitch 1,00mm gold plated pads Ø 0,50mm/.020" if pitch 0,80mm gold plated pads Ø 0,45mm/.018" if pitch 0,75mm gold plated pads Ø 0,40mm/.016" if pitch 0,65mm gold plated pads Ø 0,35mm/.012" if pitch 0,50mm gold plated pads Ø 0,25mm/.010" if pitch 0,40mm</p>

<p>Important Note:</p> <p>Please check the ball diameters & heights of your chip prior to ordering the standard E-tec BGA (BPQ) sockets. Any deviation has to be communicated to E-tec in order to check compatibility with the standard socket design and if necessary to obtain a special order code adapted to your chip dimensions.</p> <p>The standard solderball diameters & heights are the following:</p> <table border="1"> <thead> <tr> <th>Pitch</th> <th>ball diameters min/max</th> <th>ball height min/max</th> </tr> </thead> <tbody> <tr> <td>0.50mm</td> <td>0.25mm / 0.35mm</td> <td>0.20mm / 0.30mm</td> </tr> <tr> <td>0.65mm</td> <td>0.25mm / 0.45mm</td> <td>0.20mm / 0.30mm</td> </tr> <tr> <td>0.75mm</td> <td>0.25mm / 0.45mm</td> <td>0.20mm / 0.40mm</td> </tr> <tr> <td>0.80mm</td> <td>0.40mm / 0.55mm</td> <td>0.25mm / 0.45mm</td> </tr> <tr> <td>1.00mm</td> <td>0.50mm / 0.70mm</td> <td>0.30mm / 0.50mm</td> </tr> <tr> <td>1.27mm & higher</td> <td>0.60mm / 1.00mm</td> <td>0.50mm / 1.00mm</td> </tr> </tbody> </table> <p>If the minimum ball diameter of a given chip falls below the above indications, then a BUQ socket will generally be proposed.</p>	Pitch	ball diameters min/max	ball height min/max	0.50mm	0.25mm / 0.35mm	0.20mm / 0.30mm	0.65mm	0.25mm / 0.45mm	0.20mm / 0.30mm	0.75mm	0.25mm / 0.45mm	0.20mm / 0.40mm	0.80mm	0.40mm / 0.55mm	0.25mm / 0.45mm	1.00mm	0.50mm / 0.70mm	0.30mm / 0.50mm	1.27mm & higher	0.60mm / 1.00mm	0.50mm / 1.00mm	<p>Specifications</p> <p>Mechanical data</p> <p>Contact life: 10.000 cycles min. Retention System life: 10.000 cycles min. Solderability: as per IEC 60068-2-58 Individual contact force: 40 grams max.</p> <p>Material</p> <p>Insulator (RoHS compliant): High temp plastic or epoxy FR4 Terminal (RoHS compliant): Brass Contact (RoHS compliant): BeCu</p> <p>Electrical data</p> <p>Contact resistance: < 100 mΩ Current rating: 500 mA max. Insulation resistance at 500V DC: 100 MΩ if 0.50 to 0.80mm pitch, 500 MΩ 1.00mm pitch upwards</p> <p>Breakdown voltage at 60 Hz: 500V min. Capacitance: < 1 pF Inductance: < 2 nH</p> <p>Operating temperature</p> <p>-55°C to +125°C ; 260°C for 60 sec.</p>
Pitch	ball diameters min/max	ball height min/max																				
0.50mm	0.25mm / 0.35mm	0.20mm / 0.30mm																				
0.65mm	0.25mm / 0.45mm	0.20mm / 0.30mm																				
0.75mm	0.25mm / 0.45mm	0.20mm / 0.40mm																				
0.80mm	0.40mm / 0.55mm	0.25mm / 0.45mm																				
1.00mm	0.50mm / 0.70mm	0.30mm / 0.50mm																				
1.27mm & higher	0.60mm / 1.00mm	0.50mm / 1.00mm																				
<p>Recommendations:</p> <p>Solder paste – Please use a solder paste w/o any silver! E-tec solderless sockets are adapted to a standard PCB thickness of 1.60mm. For a different PCB thickness, please inform E-tec first! For high pincount SMT sockets, E-tec recommends the use of a pluggable thru-hole socket mounted into a MiniGrid Adapter (see also page 10, 11 & 12 for more details) For SMT sockets in general, E-tec recommends the use of locating pegs which can be soldered to the PCB for added mechanical strength.</p>																						

How to order

X X Q x x x x - x x x x - x x x x x L ← optional for locating pegs

<p>Device Type</p> <p>B = Ball Grid L = Land Grid C = Column Grid</p>	<p>Socket Type</p> <p>P = socket for LGA, CGA and BGA chips with standard diameter solderballs (see dimensions in table above) U = socket for small diameter solderballs</p>	<p>Pitch</p> <p>04 = 0,40mm 05 = 0,50mm 06 = 0,65mm 07 = 0,75mm 08 = 0,80mm</p> <p>10 = 1,00mm 12 = 1,27mm 15 = 1,50mm <i>others on request</i></p>	<p>Grid Code Config Code</p> <p><i>will be given by the factory after receipt of the chip datasheet</i></p> <p><i>Chips with dimensions over 36x36mm: please contact E-tec for availability first.</i></p>	<p>Plating</p> <p>95 = tin/gold (tin leadfree) 55 = gold only for Compression Type</p>
<p>Nbr of contacts</p> <p><i>depends on ballcount of chip</i></p>	<p>Contact Type</p> <p>30 = standard SMT... („A“ = 1,20mm if 1,27mm pitch; 0,80mm if 1,00mm pitch, 0,60 if 0,80mm pitch; 0,40mm if <0.80mm pitch) 29 = raised SMT.. („A“ = 5,00mm if 1,27mm pitch; 3,20mm if 1,00mm pitch; 2,80mm if 0,80mm pitch, 2,30mm if <0.80mm pitch) 28 = special raised SMT - only for 1.00 & 0.80mm pitch..... („A“ = 4,50mm) 70 = standard solder tail..... („A“ = 3.30 if 1.27mm pitch, 2.80 if 1.00mm or 0.80mm pitch, 2.30mm if <0.80mm pitch) 90 & 91 = compression type (see page 8 for more details)</p>			

Ball / Land Grid Array Sockets

LeverLock Type



E-tec is now the leading BGA socket manufacturer.

EP patents 0829188, 0897655 US patents 6190181, 6249440 Patented in other countries.

LeverLock sockets are available for a large variety of chip sizes. The SMT socket is simply placed and reflowed onto the PCB in the same way as the chip and occupies only a small amount of additional board space. The 1.27mm pitch LeverLock socket extends ≈ 6.00mm beyond the outer ball row with no fixing holes required. We aim to solve your requirements – many different terminals and configurations are available. Your custom sets our standards!

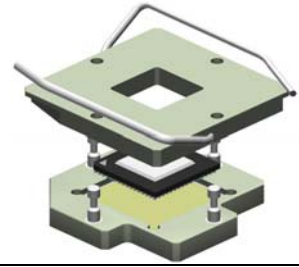

Please note, we will always request the chip data to ensure we offer a compatible socket.

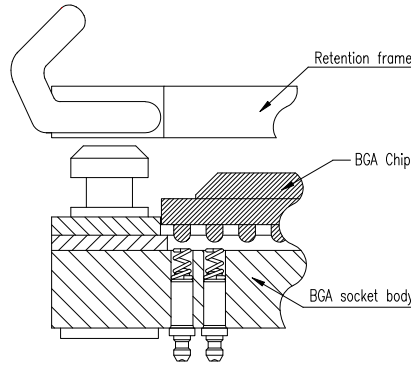
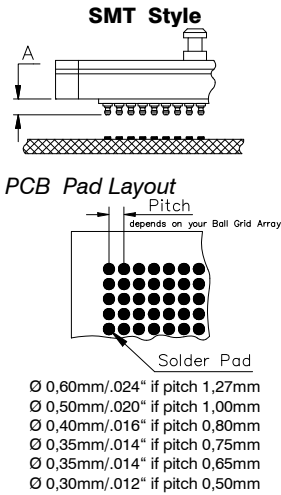

You may request any specific socket dimension from info@e-tec.com

Important Note:

Please check the ball diameters & heights of your chip prior to ordering the standard E-tec BGA (BPZ) sockets. Any deviation has to be communicated to E-tec in order to check compatibility with the standard socket design and if necessary to obtain a special order code adapted to your chip dimensions. The standard solderball diameters & heights are the following:

Pitch	ball diameters min/max	ball height min/max
0.50mm	0.25mm / 0.35mm	0.20mm / 0.30mm
0.65mm	0.25mm / 0.45mm	0.20mm / 0.30mm
0.75mm	0.25mm / 0.45mm	0.20mm / 0.40mm
0.80mm	0.40mm / 0.55mm	0.25mm / 0.45mm
1.00mm	0.50mm / 0.70mm	0.30mm / 0.50mm
1.27mm & higher	0.60mm / 1.00mm	0.50mm / 1.00mm

If the minimum ball diameter of a given chip falls below the above indications, then a BUZ socket will generally be proposed.

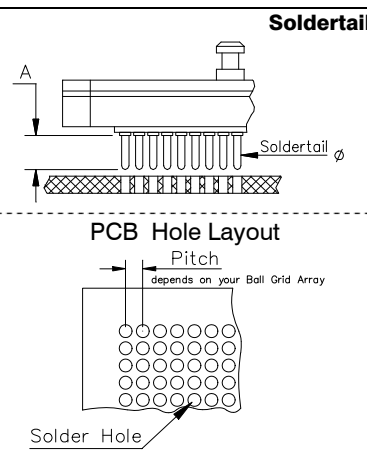

Solderetail:

\emptyset 0,42mm/.016" if pitch 1,27mm
 \emptyset 0,29mm/.011" if pitch 1,00mm
 \emptyset 0,29mm/.011" if pitch 0,80mm
 \emptyset 0,27mm/.010" if pitch 0,75mm
 \emptyset 0,27mm/.010" if pitch 0,65mm
 \emptyset 0,27mm/.010" if pitch 0,50mm
 \emptyset 0,17mm/.007" if pitch 0,40mm

PCB solder hole:

\emptyset 0.60mm/.024" if pitch 1.27mm
 \emptyset 0.50mm/.020" if pitch 1.00mm
 \emptyset 0.40mm/.016" if pitch 0.80mm
 \emptyset 0.35mm/.014" if pitch 0.75mm
 \emptyset 0.35mm/.014" if pitch 0.65mm
 \emptyset 0.35mm/.014" if pitch 0.50mm
 \emptyset 0.25mm/.010" if pitch 0.40mm

Specifications	
Mechanical data	
Contact life	10.000 cycles min.
Retention system life	1.000 cycles min.
Solderability	as per IEC 60068-2-58
Individual contact force	40 grams max.
Material	
Insulator (RoHS compliant)	High temp plastic or epoxy FR4
Terminal (RoHS compliant)	Brass
Contact (RoHS compliant)	BeCu
Electrical data	
Contact resistance	< 100 m Ω
Current rating	500 mA max.
Insulation resistance at 500V DC	100 M Ω if 0.50 to 0.80mm pitch 500 M Ω 1.00mm pitch upwards
Breakdown voltage at 60 Hz	500V min.
Capacitance	< 1 pF
Inductance	< 2 nH
Operating temperature	-55°C to +125°C ; 260°C for 60 sec.

Recommendations:

Solder paste – Please use a solder paste w/o any silver!

Solder profile – Please refer to our website www.e-tec.com

E-tec solderless sockets are adapted to a standard PCB thickness of 1.60mm. For a different PCB thickness, please inform E-tec first!

For high pincount SMT sockets, E-tec recommends the use of a pluggable thru-hole socket mounted into a MiniGrid Adapter (see also page 10, 11 & 12 for more details)

For SMT sockets in general, E-tec recommends the use of locating pegs which can be soldered to the PCB for added mechanical strength.

How to order

X X Z **x x x x** - **x x** **x x** - **x x** **X X** **x x** **L** ← optional for locating pegs

Device Type
B = Ball Grid
L = Land Grid
C = Column Grid

Socket Type
P = socket for LGA, CGA and BGA chips with standard diameter solderballs (see dimensions in table above)
U = socket for small diameter solderballs

Pitch
08 = 0,80mm
10 = 1,00mm
12 = 1,27mm
15 = 1,50mm
others on request

Grid Code	Config Code
will be given by factory after receipt of the chip datasheet.	
Chips with dimensions over 35x35mm: LeverLock not available.	
Chips with dimensions below 21x21mm: please contact E-tec for availability first.	

Plating
95 = tin/gold (tin leadfree)
55 = gold only for Compression Type

Nbr of contacts
Depends on ballcount of chip. For chips with ballcount < 100 or > 200 please contact E-tec for availability first

Contact Type
30 = standard SMT... („A“ = 1,20mm if 1,27mm pitch; 0,80mm if 1,00mm pitch, 0,60 if 0,80mm pitch; 0,40mm if <0.80mm pitch)
29 = raised SMT... („A“ = 5,00mm if 1,27mm pitch; 3,20mm if 1,00mm pitch; 2,80mm if 0,80mm pitch, 2,30mm if <0.80mm pitch)
28 = special raised SMT - only for 1.00 & 0.80mm pitch..... („A“ = 4,50mm)
70 = standard solder tail..... („A“ = 3.30 if 1.27mm pitch, 2.80 if 1.00mm or 0.80mm pitch, 2,30mm if <0.80mm pitch)
90 & 91 = compression type (see page 8 for more details)

Ball / Land Grid Array Sockets

ClamShell "Economy" Type



E-tec is now the leading BGA socket manufacturer.

EP patents 0829188, 0897655 US patents 6190181, 6249440 Patented in other countries.

Economy ClamShell sockets are available for any chip size and grid pattern. The SMT socket is simply placed and reflowed onto the PCB in the same way as the chip and occupies only a small amount of additional board space. The solderless sockets are mounted with 2 or 4 mounting pegs to the PCB depending on the chip size. The retainer uses a thumbscrew for applying the pressdown forces which does not require any tools for opening/closing of the socket. Stopper screws for setting of the pressdown forces are incorporated in this locking system and the retainer is "open top" for improved heat dissipation.

We aim to solve your requirements - many different terminals and configurations are available. Your custom sets our standards!

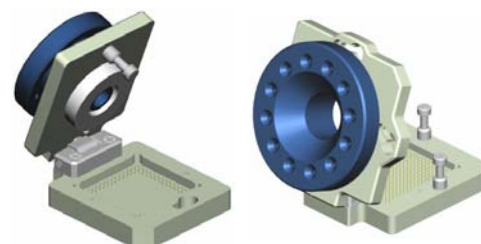

Please note, we will always request the chip data to ensure we offer a compatible socket.

low pincount style high pincount style

SMT style	Soldertail style	Solderless Compression style
<p>PCB Pad Layout</p> <p>solder pad</p> <p>Ø 0,60mm/.024" if pitch 1,27mm Ø 0,50mm/.020" if pitch 1,00mm Ø 0,40mm/.016" if pitch 0,80mm Ø 0,35mm/.014" if pitch 0,75mm Ø 0,35mm/.014" if pitch 0,65mm Ø 0,30mm/.012" if pitch 0,50mm</p>	<p>Soldertail dimension:</p> <p>Ø 0,42mm/.016" if pitch 1,27mm Ø 0,29mm/.011" if pitch 1,00mm Ø 0,29mm/.011" if pitch 0,80mm Ø 0,27mm/.010" if pitch 0,75mm Ø 0,27mm/.010" if pitch 0,65mm Ø 0,27mm/.010" if pitch 0,50mm Ø 0,17mm/.007" if pitch 0,40mm</p> <p>PCB solder hole:</p> <p>Ø 0,60mm/.024" if pitch 1,27mm Ø 0,50mm/.020" if pitch 1,00mm Ø 0,40mm/.016" if pitch 0,80mm Ø 0,35mm/.014" if pitch 0,75mm Ø 0,35mm/.014" if pitch 0,65mm Ø 0,35mm/.014" if pitch 0,50mm Ø 0,25mm/.010" if pitch 0,40mm</p>	<p>PCB Pad Layout</p> <p>Solder Pad</p> <p>You may request any specific socket dimension from info@e-tec.com</p> <p>gold plated pads Ø 0,70mm/.027" if pitch 1,27mm gold plated pads Ø 0,60mm/.024" if pitch 1,00mm gold plated pads Ø 0,50mm/.020" if pitch 0,80mm gold plated pads Ø 0,45mm/.018" if pitch 0,75mm gold plated pads Ø 0,40mm/.016" if pitch 0,65mm gold plated pads Ø 0,35mm/.012" if pitch 0,50mm gold plated pads Ø 0,25mm/.010" if pitch 0,40mm</p>

Important Note:

Please check the ball diameters & heights of your chip prior to ordering the standard E-tec BGA (BPE) sockets. Any deviation has to be communicated to E-tec in order to check compatibility with the standard socket design and if necessary to obtain a special order code adapted to your chip dimensions.

The standard solderball diameters & heights are the following:

Pitch	ball diameters min/max	ball height min/max
0.50mm	0.25mm / 0.35mm	0.20mm / 0.30mm
0.65mm	0.25mm / 0.45mm	0.20mm / 0.30mm
0.75mm	0.25mm / 0.45mm	0.20mm / 0.40mm
0.80mm	0.40mm / 0.55mm	0.25mm / 0.45mm
1.00mm	0.50mm / 0.70mm	0.30mm / 0.50mm
1.27mm & higher	0.60mm / 1.00mm	0.50mm / 1.00mm

If the minimum ball diameter of a given chip falls below the above indications, then a BUE socket will generally be proposed.

Specifications

Mechanical data

Contact life 10.000 cycles min.
 Retention System life 10.000 cycles min.
 Solderability as per IEC 60068-2-58
 Individual contact force 40 grams max.

Material

Insulator (RoHS compliant) High temp plastic or epoxy FR4
 Terminal (RoHS compliant) Brass
 Contact (RoHS compliant) BeCu

Electrical data

Contact resistance < 100 mΩ
 Current rating 500 mA max.
 Insulation resistance at 500V DC 100 MΩ if 0.50 to 0.80mm pitch
 500 MΩ 1.00mm pitch upwards

Breakdown voltage at 60 Hz 500V min.

Capacitance < 1 pF

Inductance < 2 nH

Operating temperature

-55°C to +125°C; 260°C for 60 sec.

Recommendations:

Solder paste - Please use a solder paste w/o any silver!

Solder profile - Please refer to our website www.e-tec.com

E-tec solderless sockets are adapted to a standard PCB thickness of 1.60mm. For a different PCB thickness, please inform E-tec first!

SMT ClamShell sockets are recommended to be ordered with locating pegs for soldering to the PCB, to avoid the solderjoints from being stressed during the opening/closing of the retainer. If used without locating pegs, the life cycle of the socket may be reduced.

For high pincount SMT sockets, E-tec recommends the use of a pluggable thru-hole socket mounted into a MiniGrid Adapter (see also page 10, 11 & 12 for more details)

How to order

X X E x x x x - x x x x - x x X X x x L ← optional for locating pegs

Device Type

B = Ball Grid
 L = Land Grid
 C = Column Grid

Socket Type

P = socket for LGA, CGA and BGA chips with standard diameter solderballs (see dimensions in table above)
 U = socket for small diameter solderballs

Pitch

04 = 0,40mm 10 = 1,00mm
 05 = 0,50mm 12 = 1,27mm
 06 = 0,65mm 15 = 1,50mm
 07 = 0,75mm others on request
 08 = 0,80mm

Grid Code

Config Code

will be given by the factory after receipt of the chip datasheet

Plating

95 = tin/gold (tin leadfree)
 55 = gold only for Compression Type

Nbr of contacts

depends on ballcount of chip

Contact Type

30 = standard SMT... („A“ = 1,20mm if 1,27mm pitch; 0,80mm if 1,00mm pitch, 0,60 if 0,80mm pitch; 0,40mm if <0.80mm pitch)
 29 = raised SMT... („A“ = 5,00mm if 1,27mm pitch; 3,20mm if 1,00mm pitch; 2,80mm if 0,80mm pitch, 2,30mm if <0.80mm pitch)
 28 = special raised SMT - only for 1.00 & 0.80mm pitch..... („A“ = 4,50mm)
 70 = standard solder tail..... („A“ = 3.30 if 1.27mm pitch, 2.80 if 1.00mm or 0.80mm pitch, 2,30mm if <0.80mm pitch)
 90 & 91 = compression type (see page 8 for more details)

Ball / Land Grid Array Sockets

ClamShell "Professional" Type



E-tec is now the leading BGA socket manufacturer.

EP patents 0829188, 0897655 US patents 6190181, 6249440 Patented in other countries.

Professional ClamShell sockets are available for any chip size and grid pattern. They are available in SMT, thru-hole and solderless compression type versions. The SMT socket is simply placed and reflowed onto the PCB in the same way as the chip.

We aim to solve your requirements - many different terminals and configurations are available. Your custom sets our standards!

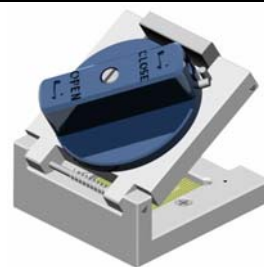

Please note, we will always request the chip data to ensure we offer a compatible socket.

SMT style	Soldertail style	Solderless Compression style
<p>PCB Pad Layout</p> <p>Pitch</p> <p>solder pad</p> <p> Ø 0,60mm/.024" if pitch 1,27mm Ø 0,50mm/.020" if pitch 1,00mm Ø 0,40mm/.016" if pitch 0,80mm Ø 0,35mm/.014" if pitch 0,75mm Ø 0,35mm/.014" if pitch 0,65mm Ø 0,30mm/.012" if pitch 0,50mm </p>	<p>PCB Hole Layout</p> <p>Pitch</p> <p>solder hole</p> <p> Soldertail dimension: Ø 0,42mm/.016" if pitch 1,27mm Ø 0,29mm/.011" if pitch 1,00mm Ø 0,29mm/.011" if pitch 0,80mm Ø 0,27mm/.010" if pitch 0,75mm Ø 0,27mm/.010" if pitch 0,65mm Ø 0,27mm/.010" if pitch 0,50mm Ø 0,17mm/.007" if pitch 0,40mm </p> <p> PCB solder hole: Ø 0,60mm/.024" if pitch 1,27mm Ø 0,50mm/.020" if pitch 1,00mm Ø 0,40mm/.016" if pitch 0,80mm Ø 0,35mm/.014" if pitch 0,75mm Ø 0,35mm/.014" if pitch 0,50mm Ø 0,25mm/.010" if pitch 0,40mm </p>	<p>Retention Cover</p> <p>BGA Chip</p> <p>BGA socket body</p> <p>PCB</p> <p>Assembly Board</p> <p>mounting screw</p> <p> PCB Pad Layout Pitch Solder Pad </p> <p>You may request any specific socket dimension from info@e-tec.com</p> <p> gold plated pads Ø 0,70mm/.027" if pitch 1,27mm gold plated pads Ø 0,60mm/.024" if pitch 1,00mm gold plated pads Ø 0,50mm/.020" if pitch 0,80mm gold plated pads Ø 0,45mm/.018" if pitch 0,75mm gold plated pads Ø 0,40mm/.016" if pitch 0,65mm gold plated pads Ø 0,35mm/.012" if pitch 0,50mm gold plated pads Ø 0,25mm/.010" if pitch 0,40mm </p>

Important Note:
Please check the ball diameters & heights of your chip prior to ordering the standard E-tec BGA (BPC) sockets. Any deviation has to be communicated to E-tec in order to check compatibility with the standard socket design and if necessary to obtain a special order code adapted to your chip dimensions.
The standard solderball diameters & heights are the following:

Pitch	ball diameters min/max	ball height min/max
0.50mm	0.25mm 0.35mm	0.20mm 0.30mm
0.65mm	0.25mm 0.45mm	0.20mm 0.30mm
0.75mm	0.25mm 0.45mm	0.20mm 0.40mm
0.80mm	0.40mm 0.55mm	0.25mm 0.45mm
1.00mm	0.50mm 0.70mm	0.30mm 0.50mm
1.27mm & higher	0.60mm 1.00mm	0.50mm 1.00mm

If the minimum ball diameter of a given chip falls below the above indications, then a BUC socket will generally be proposed.

Specifications

Mechanical data
 Contact life: 10.000 cycles min.
 Retention System life: 10.000 cycles min.
 Solderability: as per IEC 60068-2-58
 Individual contact force: 40 grams max.

Material
 Insulator (RoHS compliant): High temp plastic or epoxy FR4
 Terminal (RoHS compliant): Brass
 Contact (RoHS compliant): BeCu

Electrical data
 Contact resistance: < 100 mΩ
 Current rating: 500 mA max.
 Insulation resistance at 500V DC: 100 MΩ if 0.50 to 0.80mm pitch, 500 MΩ 1.00mm pitch upwards

Breakdown voltage at 60 Hz: 500V min.
 Capacitance: < 1 pF
 Inductance: < 2 nH

Operating temperature: -55°C to +125°C; 260°C for 60 sec.

Recommendations:

Solder paste – Please use a solder paste w/o any silver!
 E-tec solderless sockets are adapted to a standard PCB thickness of 1.60mm. For a different PCB thickness, please inform E-tec first!
 SMT ClamShell sockets are recommended to be ordered with locating pegs for soldering to the PCB, to avoid the solderjoints from being stressed during the opening/closing of the retainer. If used without locating pegs, the life cycle of the socket may be heavily reduced.
 For high pincount SMT sockets, E-tec recommends the use of a pluggable thru-hole socket mounted into a MiniGrid Adapter (see also page 10, 11 & 12 for more details)

Solder profile – Please refer to our website www.e-tec.com

How to order

X X C x x x x - x x x x - x x x x x x L ← optional for locating pegs

Device Type B = Ball Grid L = Land Grid C = Column Grid	Socket Type P = socket for LGA, CGA and BGA chips with standard diameter solderballs (see dimensions in table above) U = socket for small diameter solderballs	Pitch 04 = 0,40mm 10 = 1,00mm 05 = 0,50mm 12 = 1,27mm 06 = 0,65mm 15 = 1,50mm 07 = 0,75mm 08 = 0,80mm <i>others on request</i>	Grid Code Config Code <i>will be given by the factory after receipt of the chip datasheet</i>	Plating 95 = tin/gold (tin leadfree) 55 = gold only for Compression Type
--	---	---	--	---

Nbr of contacts <i>depends on ballcount of chip</i>	Contact Type 30 = standard SMT... („A“ = 1,20mm if 1,27mm pitch; 0,80mm if 1,00mm pitch, 0,60 if 0,80mm pitch; 0,40mm if <0.80mm pitch) 29 = raised SMT... („A“ = 5,00mm if 1,27mm pitch; 3,20mm if 1,00mm pitch; 2,80mm if 0,80mm pitch, 2,30mm if <0.80mm pitch) 28 = special raised SMT - only for 1.00 & 0.80mm pitch..... („A“ = 4,50mm) 70 = standard solder tail..... („A“ = 3.30 if 1.27mm pitch, 2.80 if 1.00mm or 0.80mm pitch, 2,30mm if <0.80mm pitch) 90 & 91 = compression type (see page 8 for more details)
---	--

Ball / Land Grid Array Sockets

ClamShell "Injection Molded" Type



E-tec is now the leading BGA socket manufacturer.

EP patents 0829188, 0897655 US patents 6190181, 6249440 Patented in other countries.

Professional ClamShell sockets "Injection Molded Type" are available for chip size and grid pattern up to 35x35. They are available in SMT, thru-hole and solderless compression type versions. The SMT socket is simply placed and reflowed onto the PCB in the same way as the chip.

We aim to solve your requirements - many different terminals and configurations are available. Your custom sets our standards!

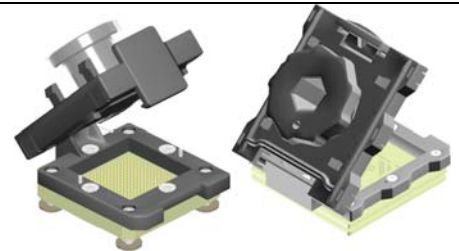

Please note, we will always request the chip data to ensure we offer a compatible socket.

SMT style	Soldertail style	Solderless Compression style
<p>PCB Pad Layout</p> <p> \varnothing 0,60mm/.024" if pitch 1,27mm \varnothing 0,50mm/.020" if pitch 1,00mm \varnothing 0,40mm/.016" if pitch 0,80mm \varnothing 0,35mm/.014" if pitch 0,75mm \varnothing 0,35mm/.014" if pitch 0,65mm \varnothing 0,30mm/.012" if pitch 0,50mm </p>	<p>PCB Hole Layout</p> <p> \varnothing 0,60mm/.024" if pitch 1,27mm \varnothing 0,50mm/.020" if pitch 1,00mm \varnothing 0,40mm/.016" if pitch 0,80mm \varnothing 0,35mm/.014" if pitch 0,75mm \varnothing 0,35mm/.014" if pitch 0,65mm \varnothing 0,35mm/.014" if pitch 0,50mm \varnothing 0,25mm/.010" if pitch 0,40mm </p>	<p>PCB Pad Layout</p> <p> You may request any specific socket dimension from info@e-tec.com </p> <p> gold plated pads \varnothing 0,70mm/.027" if pitch 1,27mm gold plated pads \varnothing 0,60mm/.024" if pitch 1,00mm gold plated pads \varnothing 0,50mm/.020" if pitch 0,80mm gold plated pads \varnothing 0,45mm/.018" if pitch 0,75mm gold plated pads \varnothing 0,40mm/.016" if pitch 0,65mm gold plated pads \varnothing 0,35mm/.012" if pitch 0,50mm gold plated pads \varnothing 0,25mm/.010" if pitch 0,40mm </p>

<p>Important Note: Please check the ball diameters & heights of your chip prior to ordering the standard E-tec BGA (BPC) sockets. Any deviation has to be communicated to E-tec in order to check compatibility with the standard socket design and if necessary to obtain a special order code adapted to your chip dimensions. The standard solderball diameters & heights are the following:</p> <table border="1"> <thead> <tr> <th>Pitch</th> <th>ball diameters min/max</th> <th>ball height min/max</th> </tr> </thead> <tbody> <tr> <td>0.50mm</td> <td>0.25mm 0.35mm</td> <td>0.20mm 0.30mm</td> </tr> <tr> <td>0.65mm</td> <td>0.25mm 0.45mm</td> <td>0.20mm 0.30mm</td> </tr> <tr> <td>0.75mm</td> <td>0.25mm 0.45mm</td> <td>0.20mm 0.40mm</td> </tr> <tr> <td>0.80mm</td> <td>0.40mm 0.55mm</td> <td>0.25mm 0.45mm</td> </tr> <tr> <td>1.00mm</td> <td>0.50mm 0.70mm</td> <td>0.30mm 0.50mm</td> </tr> <tr> <td>1.27mm & higher</td> <td>0.60mm 1.00mm</td> <td>0.50mm 1.00mm</td> </tr> </tbody> </table> <p>If the minimum ball diameter of a given chip falls below the above indications, then a BUC socket will generally be proposed.</p>	Pitch	ball diameters min/max	ball height min/max	0.50mm	0.25mm 0.35mm	0.20mm 0.30mm	0.65mm	0.25mm 0.45mm	0.20mm 0.30mm	0.75mm	0.25mm 0.45mm	0.20mm 0.40mm	0.80mm	0.40mm 0.55mm	0.25mm 0.45mm	1.00mm	0.50mm 0.70mm	0.30mm 0.50mm	1.27mm & higher	0.60mm 1.00mm	0.50mm 1.00mm	<p>Specifications</p> <p>Mechanical data Contact life: 10'000 cycles min. Retention System life: 10'000 cycles min. Solderability: as per IEC 60068-2-58 Individual contact force: 40 grams max.</p> <p>Material Insulator (RoHS compliant): High temp plastic or epoxy FR4 Terminal (RoHS compliant): Brass Contact (RoHS compliant): BeCu</p> <p>Electrical data Contact resistance: < 100 mΩ Current rating: 500 mA max. Insulation resistance at 500V DC: 100 MΩ if 0.50 to 0.80mm pitch 500 MΩ 1.00mm pitch upwards Breakdown voltage at 60 Hz: 500V min. Capacitance: < 1 pF Inductance: < 2 nH</p> <p>Operating temperature -55°C to +125°C; 260°C for 60 sec.</p>
Pitch	ball diameters min/max	ball height min/max																				
0.50mm	0.25mm 0.35mm	0.20mm 0.30mm																				
0.65mm	0.25mm 0.45mm	0.20mm 0.30mm																				
0.75mm	0.25mm 0.45mm	0.20mm 0.40mm																				
0.80mm	0.40mm 0.55mm	0.25mm 0.45mm																				
1.00mm	0.50mm 0.70mm	0.30mm 0.50mm																				
1.27mm & higher	0.60mm 1.00mm	0.50mm 1.00mm																				
<p>Recommendations: Solder paste – Please use a solder paste w/o any silver! E-tec solderless sockets are adapted to a standard PCB thickness of 1.60mm. For a different PCB thickness, please inform E-tec first! SMT ClamShell sockets are recommended to be ordered with locating pegs for soldering to the PCB, to avoid the solderjoints from being stressed during the opening/closing of the retainer. If used without locating pegs, the life cycle of the socket may be heavily reduced. For high pincount SMT sockets, E-tec recommends the use of a pluggable thru-hole socket mounted into a MiniGrid Adapter (see also page 10, 11 & 12 for more details)</p>																						

How to order

X X M x x x x - x x x x - x x X X x x L ← optional for locating pegs

<p>Device Type</p> <p>B = Ball Grid L = Land Grid</p>	<p>Socket Type</p> <p>P = socket for LGA, CGA and BGA chips with standard diameter solderballs (see dimensions in table above) U = socket for small diameter solderballs</p>	<p>Pitch</p> <p>04 = 0,40mm 05 = 0,50mm 06 = 0,65mm 07 = 0,75mm 08 = 0,80mm</p> <p>10 = 1,00mm 12 = 1,27mm 15 = 1,50mm others on request</p>	<p>Grid Code Config Code</p> <p>will be given by the factory after receipt of the chip datasheet</p>	<p>Plating</p> <p>95 = tin/gold (tin leadfree) 55 = gold only for Compression Type</p>
<p>Nbr of contacts</p> <p>depends on ballcount of chip</p>	<p>Contact Type</p> <p>30 = standard SMT... („A“ = 1,20mm if 1,27mm pitch; 0,80mm if 1,00mm pitch, 0,60 if 0,80mm pitch; 0,40mm if <0.80mm pitch) 29 = raised SMT... („A“ = 5,00mm if 1,27mm pitch; 3,20mm if 1,00mm pitch; 2,80mm if 0,80mm pitch, 2,30mm if <0.80mm pitch) 28 = special raised SMT - only for 1.00 & 0.80mm pitch..... („A“ = 4,50mm) 70 = standard solder tail..... („A“ = 3,30 if 1.27mm pitch, 2,80 if 1.00mm or 0.80mm pitch, 2,30mm if <0.80mm pitch) 90 & 91 = compression type (see page 8 for more details)</p>			

Ball / Land Grid Array Sockets

Solderless Compression Type



E-tec is now the leading BGA socket manufacturer and offers a solderless socket where board to chip contact is made without the need to solder.

EP patents 0829188, 0897655 US patents 6190181, 6249440 Patented in other countries.

Solderless compression type sockets are available for any chip size and grid pattern.

The solderless socket is easily mounted to the PCB with 4 through hole mounting pegs. The assembly board ensures perfect coplanarity of the socket. Contact reliability is guaranteed with spring loaded gold plated contacts, which are pressed onto gold plated PCB pads. Solderless compression type sockets are available with FastLock, TwistLock, "Economy" ClamShell, QuickLock, LeverLock and "Professional" ClamShell retention systems. We aim to solve your requirements - many different terminals and configurations are available. Your custom sets our standards!

Please note, we will always request the chip data to ensure we offer a compatible socket.

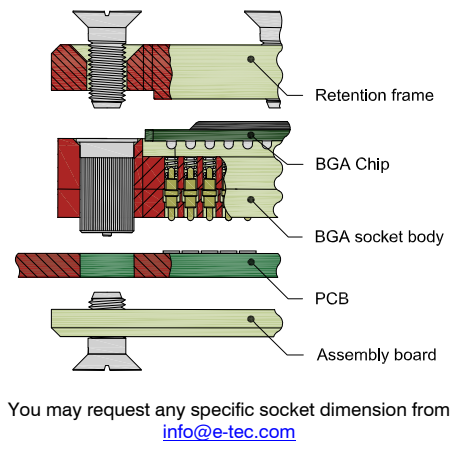
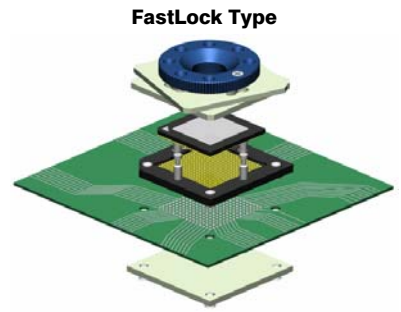

Recommendations:

PCB layout gold plated pads:
 Ø 0,70mm/.027" if pitch 1,27mm
 Ø 0,60mm/.024" if pitch 1,00mm
 Ø 0,50mm/.020" if pitch 0,80mm
 Ø 0,45mm/.018" if pitch 0,75mm
 Ø 0,40mm/.016" if pitch 0,65mm
 Ø 0,35mm/.012" if pitch 0,50mm
 Ø 0,25mm/.010" if pitch 0,40mm

PCB thickness:
 E-tec solderless sockets are adapted to a standard PCB thickness of 1.60mm.
 For a different PCB thickness, please inform E-tec first!

Important Note:
 Please check the ball diameters & heights of your chip prior to ordering the standard E-tec BGA (BPW) sockets. Any deviation has to be communicated to E-tec in order to check compatibility with the standard socket design and if necessary to obtain a special order code adapted to your chip dimensions.
 The standard solderball diameters & heights are the following:

Pitch	ball diameters min/max	ball height min/max
0.50mm	0.25mm / 0.35mm	0.20mm / 0.30mm
0.65mm	0.25mm / 0.45mm	0.20mm / 0.30mm
0.75mm	0.25mm / 0.45mm	0.20mm / 0.40mm
0.80mm	0.40mm / 0.55mm	0.25mm / 0.45mm
1.00mm	0.50mm / 0.70mm	0.30mm / 0.50mm
1.27mm & higher	0.60mm / 1.00mm	0.50mm / 1.00mm

If the minimum ball diameter of a given chip falls below the above indications, then a BUW socket will generally be proposed.

You may request any specific socket dimension from info@e-tec.com

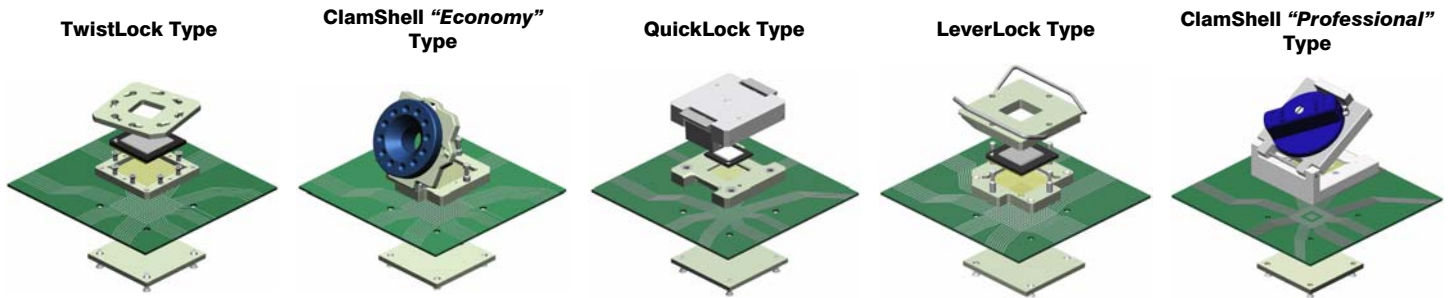

You may request any specific socket dimension from info@e-tec.com

Specifications

Mechanical data		Electrical data	
Contact life	10.000 cycles min.	Contact resistance	< 100 mΩ
Retention System life	TwistLock & LeverLock 1.000 cycles min. Fast-, QuickLock & ClamShell 10.000 cycles min.	Current rating	500 mA max.
Individual contact force	40 grams max.	Insulation resistance at 500V DC	100 MΩ if 0.50 to 0.80mm pitch 500 MΩ 1.00mm pitch upwards
Material		Breakdown voltage at 60 Hz	500V min.
Insulator (RoHS compliant)	High temp plastic or epoxy FR4	Capacitance	< 1 pF
Terminal (RoHS compliant)	Brass	Inductance	< 2 nH
Contact (RoHS compliant)	BeCu	Operating temperature	-55°C to +125°C ; 260°C for 60 sec.

How to order

X X W X X X X - X X X X - X X X X 55 L

Device Type B = Ball Grid L = Land Grid C = Column Grid	Socket Type P = socket for LGA, CGA and BGA chips with std diameter solderballs in 0.80mm pitch or higher (see dimensions in table above) U = socket for BGA chips with small diameter solderballs and for all chips with a pitch of 0.75mm or lower	Pitch 04 = 0,40mm 10 = 1,00mm 05 = 0,50mm 12 = 1,27mm 06 = 0,65mm 15 = 1,50mm 07 = 0,75mm 08 = 0,80mm <i>others on request</i>	Grid Code Config Code <i>will be given by the factory after receipt of the chip datasheet</i>	Plating 55 = gold
Locking Type F = FastLock C = ClamShell "Professional" Type E = ClamShell "Economy" Type Q = QuickLock W = TwistLock Z = LeverLock	Nbr of contacts <i>depends on ballcount of chip</i>	Option 90 = standard probes up to 3 GHz 91 = high speed probes exceeding 10 GHz		

E-tec is now the leading BGA socket manufacturer.

These elastomer interposer sockets are available for any chip size and pitch. The standard version is the solderless socket style, which is attached with 2 or 4 screws to the PCB. SMT and thru-hole adapter sockets are available in certain pitches (contact factory for availability first) with these elastomer interposers to allow using this high frequency interposer on PCB's which have already been laid out for SMT or thru-hole sockets. The retainer can be delivered with a center opening for die access and the socket outline will be kept to a minimum and special clearances can be offered to avoid components on the PCB.

We aim to solve your requirements - your custom sets our standards!

Please note, we will always request the chip data to ensure we offer a compatible socket.

BGA/LGA/QFN Chip Socket

GullWing Chip Socket

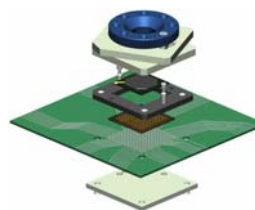

FastLock Type

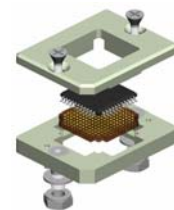

ScrewLock Type

Solderless Compression style Standard Version

(FastLock Type as example only - other locking systems available also)

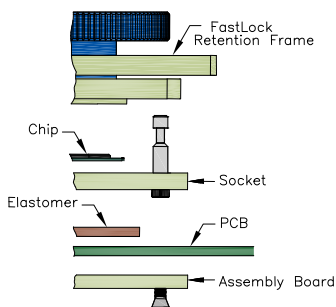
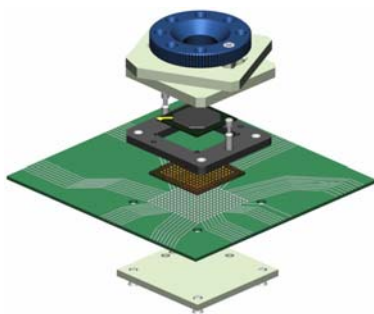

- gold plated pads Ø 0,70mm/.027" if pitch 1,27mm
- gold plated pads Ø 0,60mm/.024" if pitch 1,00mm
- gold plated pads Ø 0,50mm/.020" if pitch 0,80mm
- gold plated pads Ø 0,45mm/.018" if pitch 0,75mm
- gold plated pads Ø 0,40mm/.016" if pitch 0,65mm
- gold plated pads Ø 0,30mm/.012" if pitch 0,50mm

Important Note:

PCB pad height: same or higher than solder mask.
PCB thickness: 1.60mm std. (others: contact E-tec)

Elastomer Specifications

Flammability: UL 94V-0
Current rating at minimum 0.10mm compression depends on solderball size:

0.30mm dia balls	1A min.
0.60mm dia balls	2A min.
Insulation resistance :	1000 MΩ
Contact resistance :	< 50 mΩ
Capacitance :	< 0.3 pF
Inductance :	< 0.6 nH
Breakdown voltage :	500V DC
Operating temperature :	-35°C to +125°C

Bandwidth

0.50mm thick elastomer	sinusoidal signals : -1dB at >10 GHz digital signals: 10 GHz min.
1.00mm thick elastomer	sinusoidal signals: -1dB at >10 GHz digital signals: up to 6.5GHz max.

Recommended Compression: 0.10mm min.

Compression forces

0.50mm thick elastomer	Solderball diameters
	0.50mm = 40 to 50gf @0.20mm
	0.60mm = 60 to 80gf @0.20mm
	0.75mm = 90 to 120gf @0.20mm
1.00mm thick elastomer	Solderball diameters
	0.50mm = 40 to 50gf @0.20mm
	0.60mm = 50 to 70gf @0.20mm
	0.75mm = 90 to 120gf @0.20mm

Mechanical data

Elastomer life	BGA chips :	1.000 cycles min.
	LGA/QFN chips :	10.000 cycles min.

Dimensions & Tolerances

Pitch of wires	P1 & P2 = 0.05mm x 0.05mm to 0.10mm x 0.10mm (depending on pitch of chip)
Thickness/Offset	T = 0.50mm (±0.05mm)/Offset = 0.25mm (±0.05mm) T = 1.00mm (±0.07mm)/Offset = 0.50mm (±0.07mm)
Width/Length	min. = 3.00mm x 3.00mm (±0.50mm) max. = 49.00mm x 49.00mm (±0.50mm)

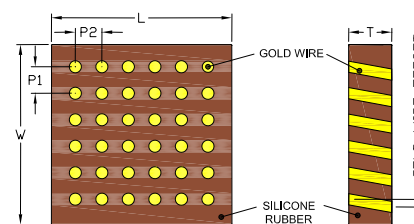

Locking systems overview (not exhaustive)

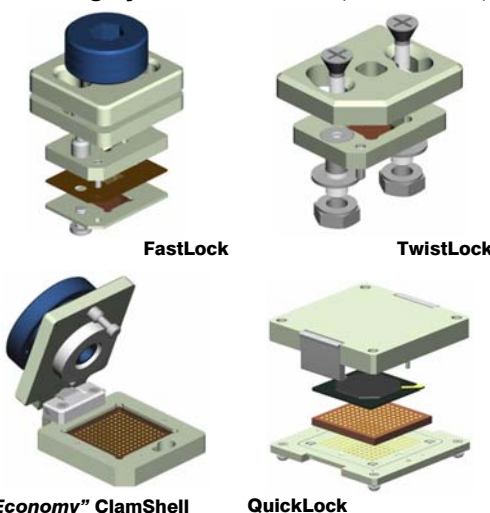

Special Elastomer Adapters (on request)

SMT and THT (Soldertail) Adapter Style on request

(FastLock Type as example only - other locking systems available also)

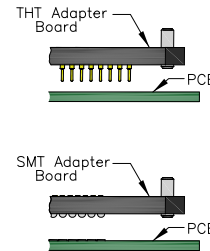
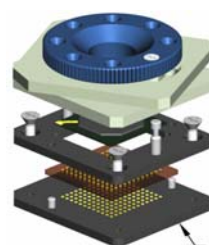

Recommendations for SMT Adapter Boards

Solder paste Please use a solder paste w/o any silver!
Solder profile Please refer to our website www.e-tec.com

How to order

E X X x x x x - x x x x - x x X X x x L ← locating pegs

Device Type B = BGA L = LGA/QFN G = GullWing	Locking Type W = TwistLock F = FastLock Q = QuickLock E = ClamShell "Economy" Type for BGA/LGA/QFN For GullWing type contact factory. Lifetime: TwistLock 1K cycles min. all others 10K cycles min.	Nbr of contacts 999 if LGA or QFN Ball count if BGA	Elastomer or Pitch will be given by the factory after receipt of the chip datasheet	Grid Code will be given by the factory after receipt of the chip datasheet	Config Code	Plating 55 = gold if with adapterboard 95 = tin/gold (tin leadfree)
---	---	--	---	--	--------------------	---

Contact Type

- 90** = Solderless Compression Type; 6.5 GHz performance
- 91** = Solderless Compression Type; 10 GHz performance others on request
- Solder Adapters (on request only):**
- 30** = SMT..... (with surface mount Adapterboard)
- 70** = THT..... (with soldertail Adapterboard)

BGA emulation adapter allows BGA socket to be inserted.

The SMT adapter is available either with solder ball or with solid pin terminals. This SMT adapter emulates the chip's BGA footprint and is easily installed using standard flux and reflow techniques. The solder ball adapters have the same solder ball types as the IC's they are emulating. You can combine the SMT foot with any of the E-tec socket styles shown in the Test Socket Catalog pages 1 through 7. The corresponding male BGA socket, through hole type, is plugged into the adapter.

We offer any pin-out, configuration and grid size for pitch 0.8mm, 1.00mm and 1.27mm.

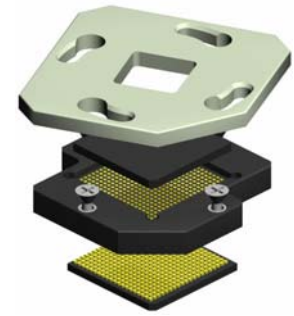

BGA Socket with SMT Adapter

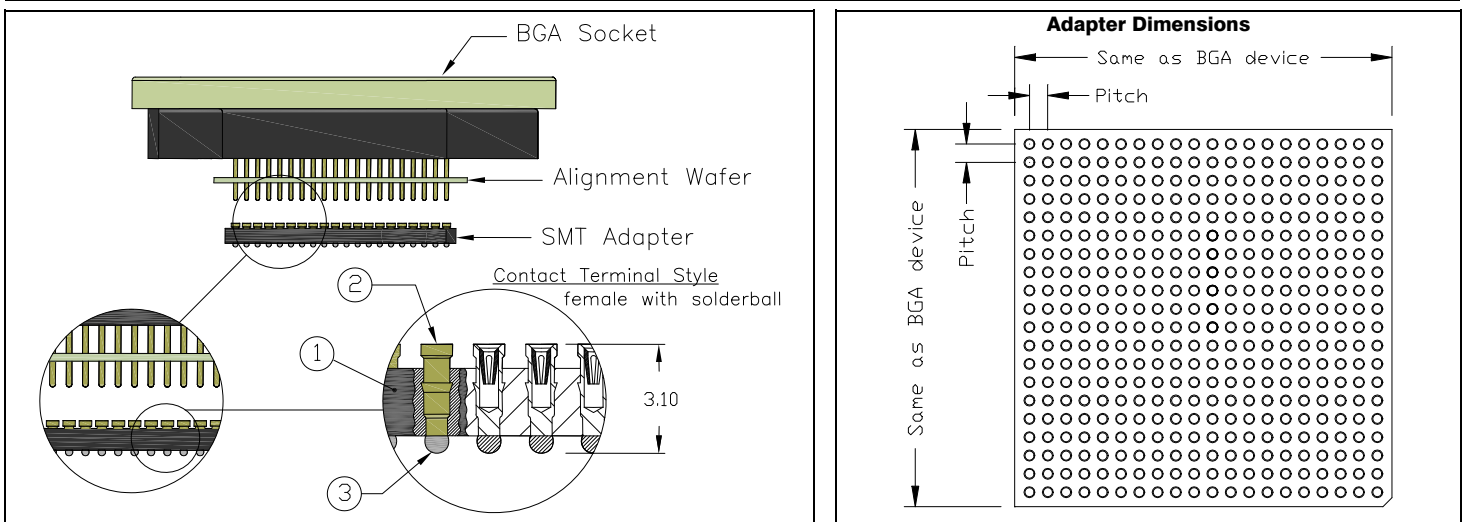

Specifications

1 Insulator (Adapter Wafer)	Material: FR4/G10 or equivalent high temp material (RoHS compliant)
2 Contact (Terminal & Contact Clip) (accepts 0.20mm-0.30mm diameter pins)	Material: Terminal CuZn (RoHS compliant) Contact Clip BeCu (RoHS compliant)
3 Solder Ball	Material: Sn63Pb 37 (NON RoHS compliant) Sn96.5 Ag 3.0 Cu 0.5 (RoHS compliant)

Operating Temperature: -55°C to +125°C Processing Temperature: 260°C for 60 sec. Insertion force: 0.45N Extraction force: 0.25N

How to order

MGS xxxx - SB01 - xx X xx xx

Nbr of contacts/balls as per device	Contact Terminal styles	Grid size	Config Code	Contact Plating & Solder Ball Alloy	Pitch of Grid Array
	<p>Solder Ball Terminal SB01 = standard size (see drawing above)</p> <p>Solid Pin Terminals E119 please refer to the BGA Mini-Grid socket page 12 E167 E169</p>				

E-tec will supply the corresponding BGA sockets for plugging into these adapters, which will be delivered with gold plated thru-hole pins and a pin alignment wafer for easy insertion. Please choose the socket style you wish to plug into these adapters from the catalog pages 1 through 7 and request from E-tec the contact style "70" (thru-hole pin), with the plating code to "55" (gold) and with the adder "A" for the alignment plate (XXXxxxx-xx70-xxXX55A). Example: BPW256-1070-16AA55A for a 256-pin TwistLock socket (page 2). For 1.27mm pitch sockets a special thru-hole pin -1272- will be offered. Alternatively the MiniGrid adapters (ABG series - see page 11) can also be supplied together with these SMT BGA emulation adapters.

Please contact E-tec for any further information.

The E-tec BGA Adapter System comprises two elements, the BGA solder adapter onto which the BGA chip is soldered (converting the BGA chip to a PGA), and the MiniGrid Socket which is soldered to the PCB. The solder adapter can then be plugged into the MiniGrid Socket (page 10 or 12).

E-tec offers any pin-out, configuration and grid size.
Special terminal designs are possible on request.

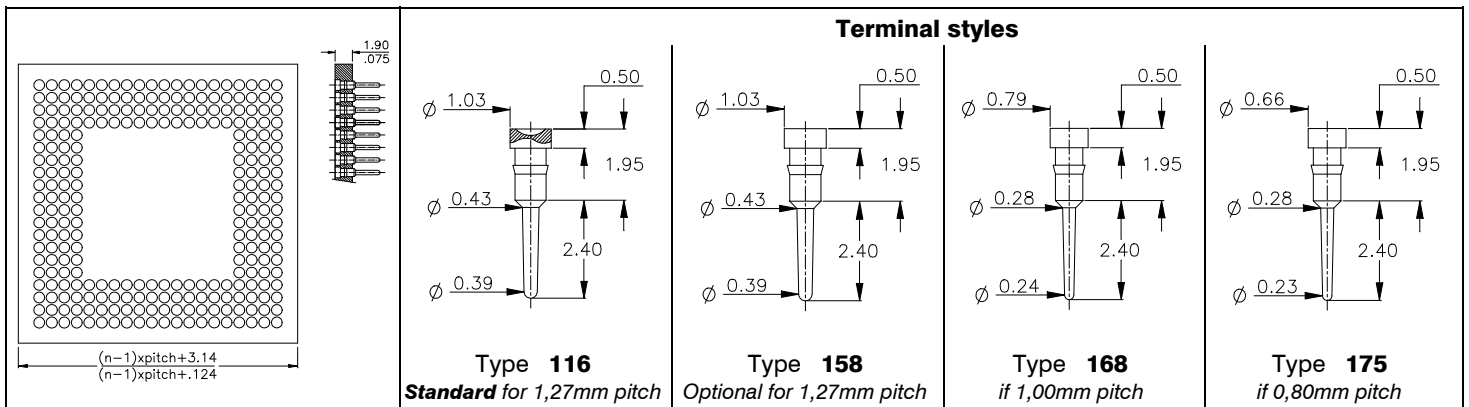
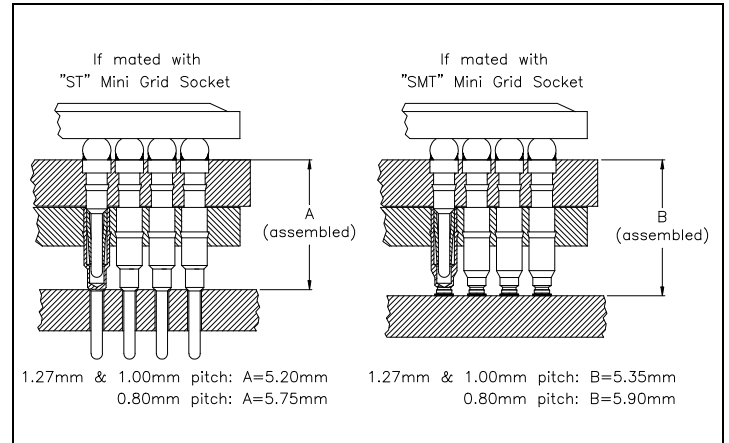
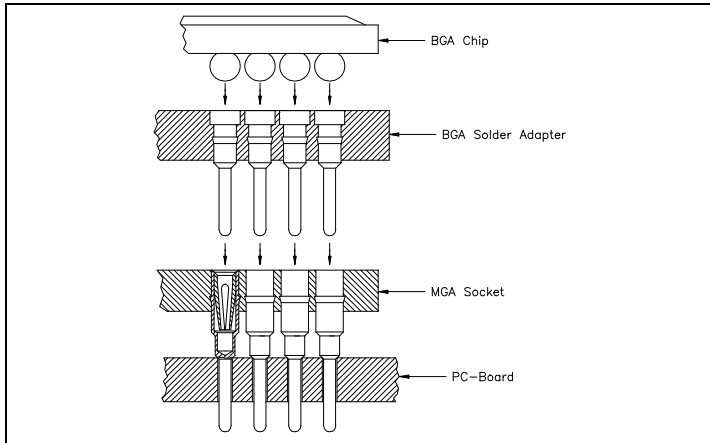
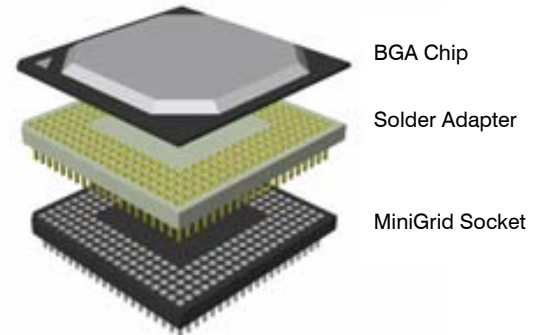

Specifications

Terminal Type	Material	Plating	Adapter	Others
116, 158, 168 & 175	CuZn	Au over Ni over Cu	Material : FR 4 glass Epoxy UL 94V-0	Operating Temperature : -55°C to +125°C ; 260°C for 60 sec.

How to order

ABG xxxx - E xxx - xx X 55 xx

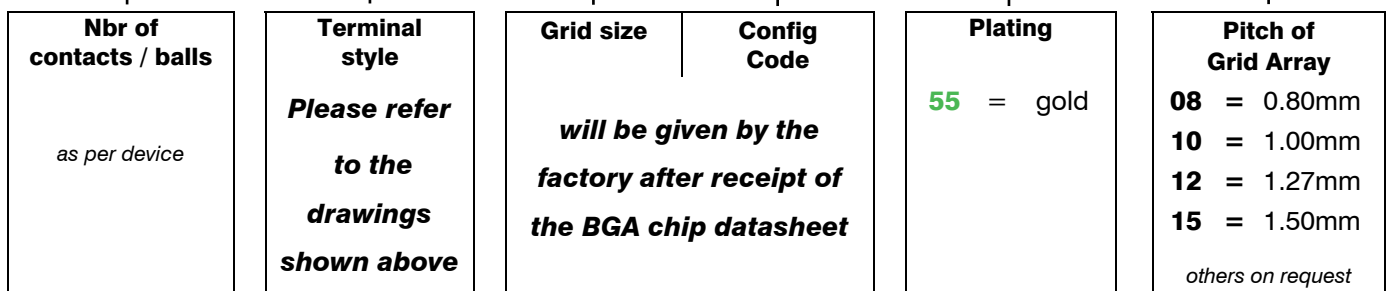

The E-tec MiniGrid Socket is soldered to the target board and is designed to accept the BGA Solder Adapter (where the chip is soldered to the adapter board). As an alternative, this MiniGrid Socket is also designed to accept the “true” through hole BGA Sockets (where the chips can be socketed without soldering).

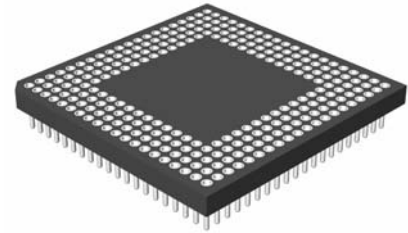

E-tec offers any pin-out, configuration and grid size.
Special terminal designs are possible on request.

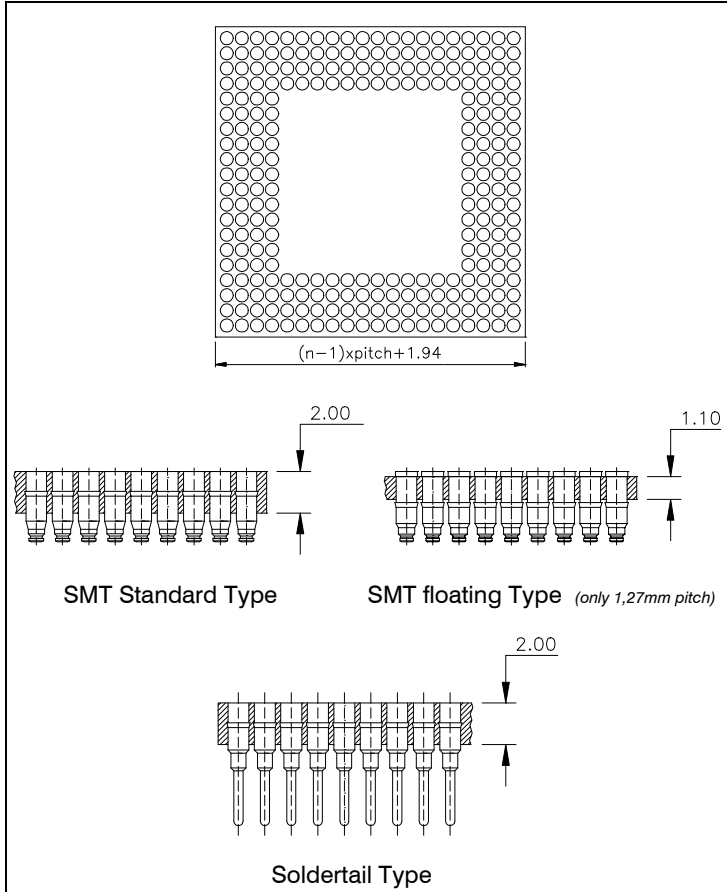

Terminal styles			
 SMT Terminal Type 119 if 1,27 ; 1,50 & 2,00mm pitch	 SMT „floating” Type 120 if 1,27 ; 1,50 & 2,00mm pitch	 SMT Terminal Type 167 if 1,00mm pitch	 SMT Terminal Type 169 if 0,80mm pitch
 Solder Tail Terminal Type 117 if 1,27 ; 1,50 & 2,00mm pitch	 Solder Tail Terminal Type 172 if 1,00mm pitch	 Solder Tail Terminal Type 174 if 0,80mm pitch	

Specifications				
Terminal Type 117, 119, 120, 167 169, 172, 174	Material Terminal : CuZn Contact clip : BeCu	Plating Sn over Ni over Cu Au over Ni over Cu	Socket Material FR 4 glass Epoxy UL 94V-0	Others Operating Temperature -55°C to +125°C ; 260°C for 60 sec.

How to order

MGS xxxx - E xxx - xx X 95 xx

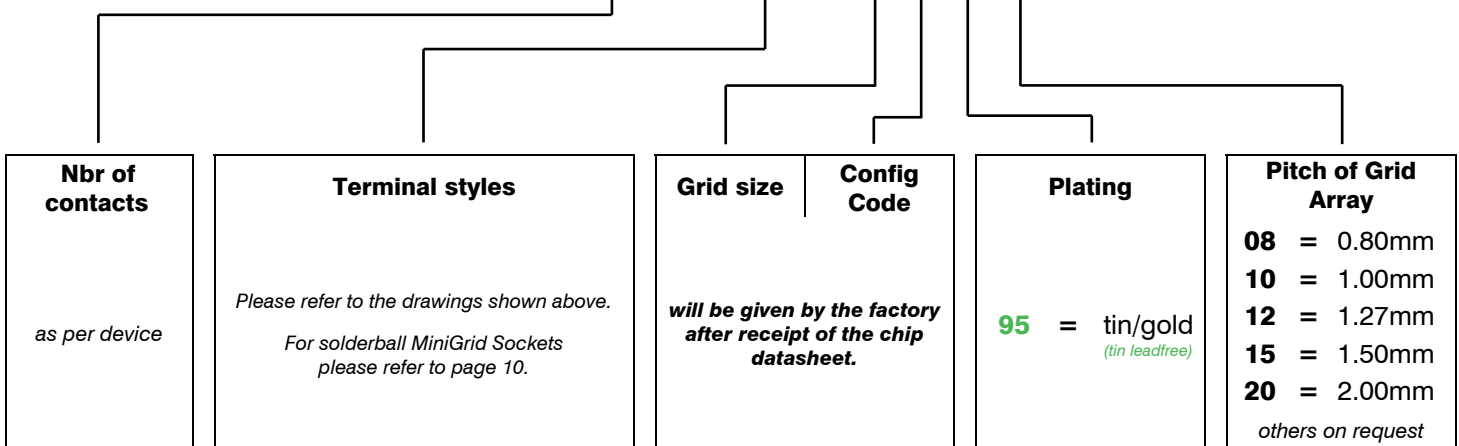

E-tec is now the leading BGA socket manufacturer.

EP patents 0829188, 0897655 US patents 6190181, 6249440 Patented in other countries.

QFN/MLF/MLP sockets are available for any chip size and pitch. They are available in SMT, thru-hole and solderless compression type versions. The SMT socket is simply placed and reflowed onto the PCB in the same way as the chip and it only requires a small amount of additional board space. The retainer can be delivered with a center opening for die access. Additional center grounding pins are offered on request.

We aim to solve your requirements - your custom sets our standards!

Please note, we will always request the chip data to ensure we offer a compatible socket.

FastLock Type

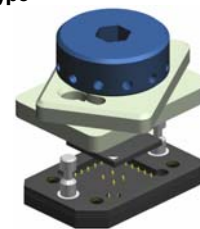

SMT style	Soldertail style	Solderless Compression style (TwistLock Type as example shown)
<p>PCB Pad Layout</p> <p>Pitch</p> <p>optional for grounding</p> <p>solder pad</p> <p>Ø 0,60mm/.024" if pitch 1,27mm Ø 0,50mm/.020" if pitch 1,00mm Ø 0,40mm/.016" if pitch 0,80mm Ø 0,35mm/.014" if pitch 0,75mm Ø 0,35mm/.014" if pitch 0,65mm Ø 0,30mm/.012" if pitch 0,50mm</p>	<p>Soldertail dimension:</p> <p>Ø 0,42mm/.016" if pitch 1,27mm Ø 0,29mm/.011" if pitch 1,00mm Ø 0,29mm/.011" if pitch 0,80mm Ø 0,27mm/.010" if pitch 0,75mm Ø 0,27mm/.010" if pitch 0,65mm Ø 0,27mm/.010" if pitch 0,50mm Ø 0,17mm/.007" if pitch 0,40mm</p> <p>PCB solder hole:</p> <p>Ø 0,60mm/.024" if pitch 1,27mm Ø 0,50mm/.020" if pitch 1,00mm Ø 0,40mm/.016" if pitch 0,80mm Ø 0,35mm/.014" if pitch 0,75mm Ø 0,35mm/.014" if pitch 0,65mm Ø 0,35mm/.014" if pitch 0,50mm Ø 0,25mm/.010" if pitch 0,40mm</p>	<p>Retention frame</p> <p>QFN Device</p> <p>Socket body</p> <p>PCB</p> <p>Assembly board</p> <p>PCB Pad Layout</p> <p>Pitch</p> <p>optional for grounding</p> <p>PCB land</p> <p>You may request any specific socket dimension from info@e-tec.com</p> <p>gold plated pads Ø 0,70mm/.027" if pitch 1,27mm gold plated pads Ø 0,60mm/.024" if pitch 1,00mm gold plated pads Ø 0,50mm/.020" if pitch 0,80mm gold plated pads Ø 0,45mm/.018" if pitch 0,75mm gold plated pads Ø 0,40mm/.016" if pitch 0,65mm gold plated pads Ø 0,35mm/.012" if pitch 0,50mm gold plated pads Ø 0,25mm/.010" if pitch 0,40mm</p>

FastLock Solderless Compression Type	TwistLock Solderless Compression Type	ClamShell "Economy" Type	QuickLock Type	Specifications
				<p>Mechanical data</p> <p>Contact life: 10.000 cycles min.</p> <p>Retention System life: TwistLock 1.000 cycles min., ClamShell, Fast- & QuickLock 10.000 cycles min.</p> <p>Solderability: as per IEC 60068-2-58</p> <p>Individual contact force: 40 grams max.</p> <p>Material</p> <p>Insulator (RoHS compliant): High temp plastic or epoxy FR4</p> <p>Terminal (RoHS compliant): Brass</p> <p>Contact (RoHS compliant): BeCu</p> <p>Electrical data</p> <p>Contact resistance: < 100 mΩ</p> <p>Current rating: 500 mA max.</p> <p>Insulation resistance at 500V DC: 100 MΩ if 0.50 to 0.80mm pitch, 500 MΩ 1.00mm pitch upwards</p> <p>Breakdown voltage at 60 Hz: 500V min.</p> <p>Capacitance: < 1 pF</p> <p>Inductance: < 2 nH</p> <p>Operating temperature</p> <p>-55°C to +125°C ; 260°C for 60 sec.</p>

Recommendations:

Solder paste – Please use a solder paste w/o any silver!

Solder profile – Please refer to our website www.e-tec.com

E-tec solderless sockets are adapted to a standard PCB thickness of 1.60mm. For a different PCB thickness, please inform E-tec first!

SMT sockets are recommended to be ordered with locating pegs for soldering to the PCB, to avoid the solderjoints from being stressed due to the torque forces applied with this locking system. If used without locating pegs, the life cycle of the socket may be heavily reduced.

How to order

L Q X x x x x - x x x x - x x x x x x L ← optional for locating pegs

Locking Type	Nbr of contacts	Pitch	Grid Code	Config Code	Plating
<p>W = TwistLock</p> <p>F = FastLock</p> <p>Q = QuickLock</p> <p>E = ClamShell "Economy" Type</p> <p>Others on request</p>	<p>depends on landcount of chip, plus center grounding pins if required. (generally 4 pins)</p>	<p>04 = 0,40mm 10 = 1,00mm</p> <p>05 = 0,50mm 12 = 1,27mm</p> <p>06 = 0,65mm</p> <p>07 = 0,75mm</p> <p>08 = 0,80mm</p> <p>Others on request</p>	<p>will be given by the factory after receipt of the chip datasheet</p>	<p>will be given by the factory after receipt of the chip datasheet</p>	<p>95 = tin/gold (tin leadfree)</p> <hr/> <p>55 = gold only for solderless Compression Type</p>

Contact Type

- 30** = standard SMT.... („A“ = 1,20mm if 1,27mm pitch; 0,80mm if 1,00mm pitch, 0,60 if 0,80mm pitch; 0,40mm if <0,80mm pitch)
- 29** = raised SMT... („A“ = 5,00mm if 1,27mm pitch; 3,20mm if 1,00mm pitch; 2,80mm if 0,80mm pitch, 2,30mm if <0,80mm pitch)
- 28** = special raised SMT - only for 1.00 & 0.80mm pitch..... („A“ = 4,50mm)
- 70** = standard solder tail..... („A“ = 3.30 if 1.27mm pitch, 2.80 if 1.00mm or 0.80mm pitch, 2.30mm if <0.80mm pitch)
- 90 & 91** = compression type (see page 8 for more details)

"GullWing Chip" Sockets

Screw-, Fast-, QuickLock & ClamShell Type



GullWing sockets are available for any GullWing type chips (QFP, PQFP, SOIC, SO etc.) and lead pattern. The sockets are available for any pin-out and tip-to-tip dimension as of 0.50mm pitch upwards. The SMT socket is simply placed and reflowed onto the PCB in the same way as the chip and it only requires a small amount of additional board space. The standard locking system is the ScrewLock design, but QuickLock and ClamShell locking systems are also available.

We aim to solve your requirements - many different terminals and configurations are available.

Your custom sets our standards!

Please note, we will always request the chip data to ensure we offer a compatible socket.

ScrewLock Type

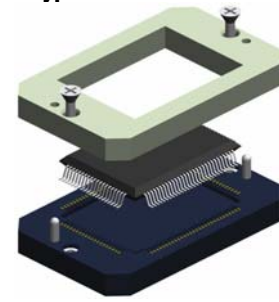

SMT style

PCB Pad Layout

Pitch

solder pad

- Ø 0,50mm/.020" if pitch 1,27mm
- Ø 0,50mm/.020" if pitch 1,00mm
- Ø 0,40mm/.016" if pitch 0,80mm
- Ø 0,35mm/.014" if pitch 0,75mm
- Ø 0,35mm/.014" if pitch 0,65mm
- Ø 0,30mm/.012" if pitch 0,50mm

Soldertail style

PCB Hole Layout

Pitch

solder hole

Soldertail dimension:

- Ø 0,29mm/.011" if pitch 1,27mm
- Ø 0,29mm/.011" if pitch 1,00mm
- Ø 0,29mm/.011" if pitch 0,80mm
- Ø 0,27mm/.010" if pitch 0,75mm
- Ø 0,27mm/.010" if pitch 0,65mm
- Ø 0,27mm/.010" if pitch 0,50mm

PCB solder hole:

- Ø 0,50mm/.020" if pitch 1,27mm
- Ø 0,50mm/.020" if pitch 1,00mm
- Ø 0,40mm/.016" if pitch 0,80mm
- Ø 0,35mm/.014" if pitch 0,75mm
- Ø 0,35mm/.014" if pitch 0,65mm
- Ø 0,35mm/.014" if pitch 0,50mm

Solderless Compression style

You may request any specific socket dimension from info@e-tec.com

- gold plated pads Ø 0,60mm/.024" if pitch 1,27mm
- gold plated pads Ø 0,60mm/.024" if pitch 1,00mm
- gold plated pads Ø 0,50mm/.020" if pitch 0,80mm
- gold plated pads Ø 0,45mm/.018" if pitch 0,75mm
- gold plated pads Ø 0,40mm/.016" if pitch 0,65mm
- gold plated pads Ø 0,35mm/.012" if pitch 0,50mm

Quick Lock Type	FastLock Type	ClamShell Type
without lever for low leadcount chips	with lever for high leadcount chips	adapted to low and high leadcount chips
		with center screw for high leadcount chips

Specifications

Mechanical data

- Contact life: 10.000 cycles min.
- Retention System life: 1.000 cycles min.
- ScrewLock: 10.000 cycles min.
- ClamShell, Fast- & QuickLock: as per IEC 60068-2-58
- Solderability: 40 grams max.
- Individual contact force: 40 grams max.

Material

- Insulator (RoHS compliant): High temp plastic or epoxy FR4
- Terminal (RoHS compliant): Brass
- Contact (RoHS compliant): BeCu

Electrical data

- Contact resistance: < 100 mΩ
- Current rating: 500 mA max.
- Insulation resistance at 500V DC: 100 MΩ if 0.50 to 0.80mm pitch; 500 MΩ 1.00mm pitch upwards
- Breakdown voltage at 60 Hz: 500V min.
- Capacitance: < 1 pF
- Inductance: < 2 nH

Operating temperature

- 55°C to +125°C ; 260°C for 60 sec.

Recommendations:

Solder paste – Please use a solder paste w/o any silver!
 Solder profile – Please refer to our website www.e-tec.com

E-tec solderless sockets are adapted to a standard PCB thickness of 1.60mm. For a different PCB thickness, please inform E-tec first!
 The SMT sockets are mounted with straight SMT pins (not bent legs), which are adapted to round PCB pads. For rectangular PCB pads, please ensure that the round socket pins will be surface mountable, since E-tec cannot offer any guarantee in such instances.
 For SMT sockets in general, E-tec recommends the use of locating pegs, which can be soldered to the PCB for added mechanical strength.

How to order

QF X x x x x - x x x x - x x x x x x L ← optional for locating pegs

Retention Type	Nbr of contacts	Pitch	Grid Code	Config Code	Plating
W = ScrewLock F = FastLock Q = QuickLock C = ClamShell	depends on leadcount of chip	05 = 0,50mm 06 = 0,65mm 07 = 0,75mm 08 = 0,80mm 10 = 1,00mm 12 = 1,27mm others on request	will be given by the factory after receipt of the chip datasheet		95 = tin/gold (tin leadfree) <hr/> 55 = gold only for solderless Compression Type

Contact Type

- 30** = standard SMT... („A“ = 0,80mm if 1,27mm pitch or 1,00mm pitch, 0,60 if 0,80mm pitch; 0,40mm if <0,80mm pitch)
- 29** = raised SMT... („A“ = 3,20mm if 1,27mm pitch or 1,00mm pitch; 2,80mm if 0,80mm pitch, 2,30mm if <0,80mm pitch)
- 28** = special raised SMT - only for 1,27, 1,00 & 0,80mm pitch..... („A“ = 4,50mm)
- 70** = standard solder tail..... („A“ = 2,80 if 1,27mm pitch, 1,00mm or 0,80mm pitch; 2,30mm if <0,80mm pitch)
- 90 & 91** = compression type (see page 8 for more details)

Heatsinks for BGA & LGA sockets

Standard & customized Heatsinks (with or without integrated fan) adapted to BGA & LGA sockets are available on request

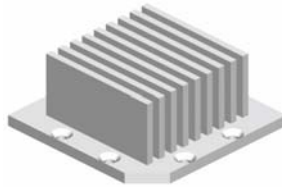
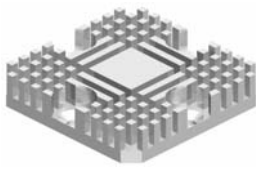

For order code please contact www.e-tec.com

LGA to BGA converter plates

For applications where a chip is tested with & without solderballs the LGA sockets can be delivered with a converter plate to allow socketing BGA chips with an LGA socket.

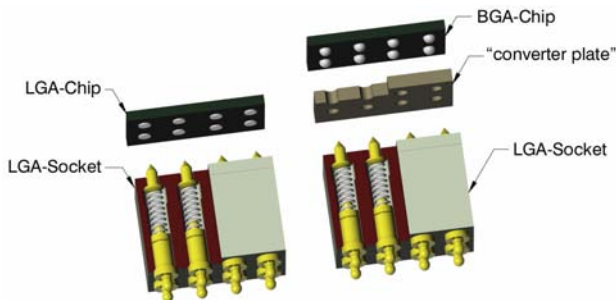

For order code please contact www.e-tec.com

Thermo couple attachment feature

E-tec TwistLock sockets are available with a thermo couple attachment feature on request

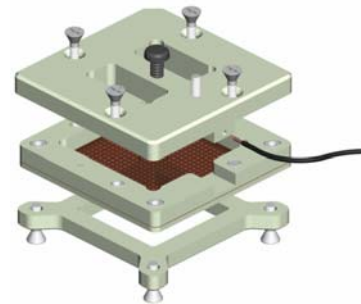

For order code please contact www.e-tec.com

“Torque Limiting Screwdriver Kit” for E-tec BGA “TwistLock Sockets”

E-tec recommends the use of this pre-set adjustable torque screw driver for correct tightening of the E-tec BGA/LGA socket retention frames. Excess tightening can be completely avoided with the use of this screw driver, which comes with a stainless steel shaft and attractive coloured aluminium handle.



The Kit includes:
1 – Torque Limiting Screwdriver
1 – 0 Point Philips Bit 1-15/16“

Order Code:
TOL – 7CN – TORQUE

Special clearances in socket body and stiffener boards

If you need any special clearance for components on the PCB (top side or bottom side), E-tec can easily adapt the socket to your requirements.

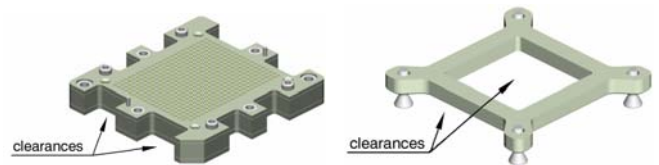

Socket body with clearances

Assembly/stiffener board with clearances

For order code please contact www.e-tec.com

“Torque Tool Fixture” for E-tec BGA “FastLock Sockets”



For order code please contact www.e-tec.com

Ultra slim socket profile

In case of limited space on the PCB, E-tec can reduce the socket size to a minimum, based on customer request.

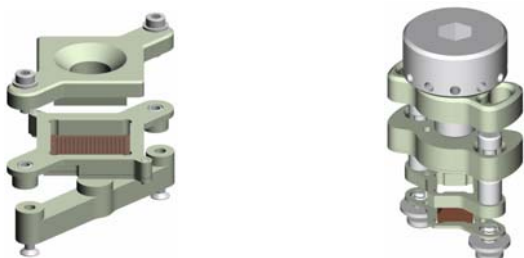

For order code please contact www.e-tec.com

Socket with “interchangeable” chip positioning frames

For chips with same pincount, but different body sizes, E-tec offers interchangeable chip positioning frames to allow the use of one single socket.

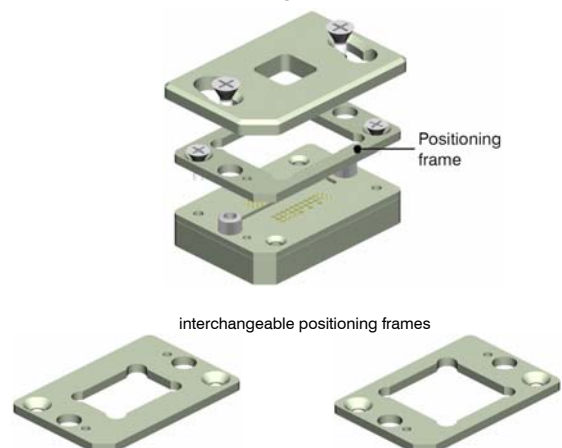

For order code please contact www.e-tec.com

Contact E-tec for any other special feature you may require with the sockets. We will attempt to fulfil your needs!

ZIF Test Sockets for Flex Cable

0.50mm to 2.54mm pitch



High cycle ZIF Test Sockets for any kind and pitch of Flex-Cable.

Handles up to 10K cycles with simple open/close ClamShell type retention frame.

Cable Dimensions

In order to be able to offer the correct socket for your cable, we need to know the type of cable you are using and the corresponding dimensions as shown below.

Please send the datasheet of your cable together with your socket request.

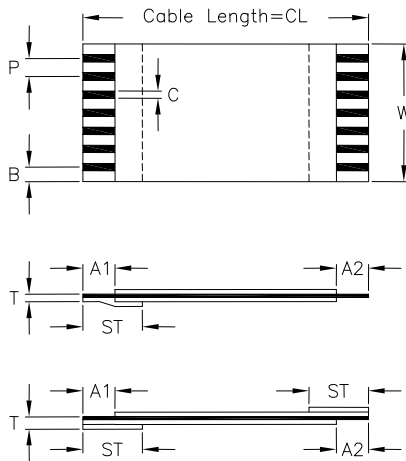

Specifications

Mechanical data

Contact life
Retention System life
Solderability
Individual contact force

10.000 cycles min.
10.000 cycles min.
as per IEC 60068-2-58
40 grams max.

Material

Insulator (RoHS compliant)
Terminal (RoHS compliant)
Spring (RoHS compliant)

High temp plastic or epoxy FR4
Brass
BeCu

Electrical data

Contact resistance
Current rating
Insulation resistance at 500V DC

Breakdown voltage at 60 Hz
Capacitance
Inductance

< 100 mΩ
500 mA max.
100 MΩ if 0.50 to 0.80mm pitch
500 MΩ 1.00mm pitch upwards
500V min.
< 1 pF
< 2 nH

Operating temperature

-55°C to +125°C

Processing temperature

260°C for 60sec.

A detailed socket drawing with the required PCB layout dimensions will be submitted by E-tec for each project.

How to order

FCT - x xx - X xxx - xx

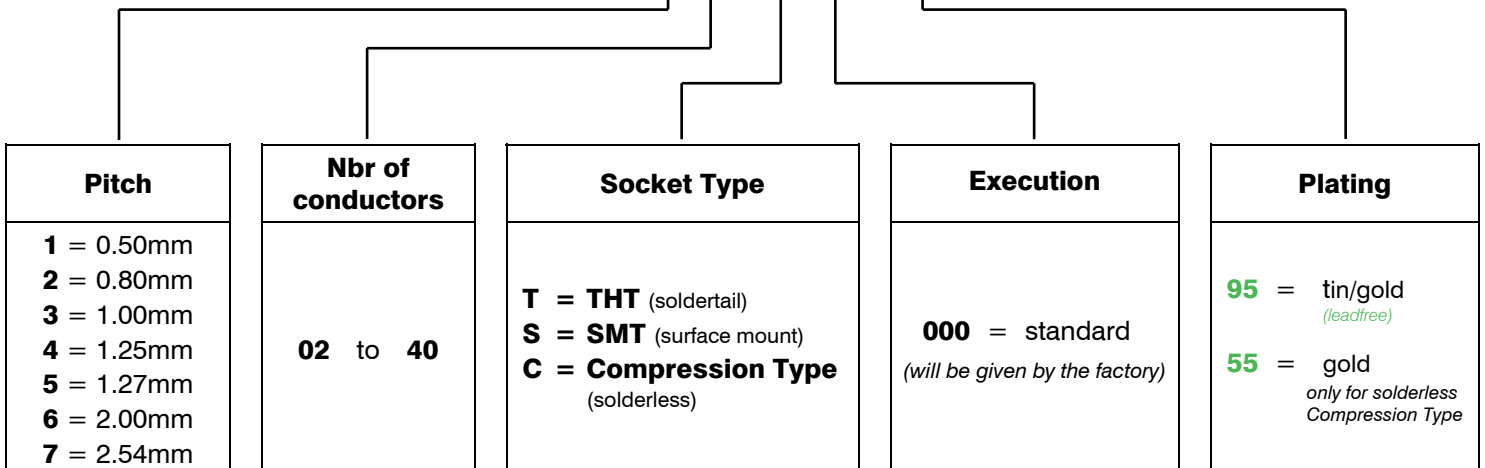

Other products from E-tec

Please contact your closest sales office for further information.



Insertion-Extraction Tools

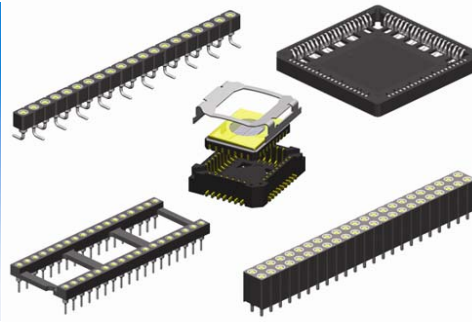

IC - Sockets



Switches

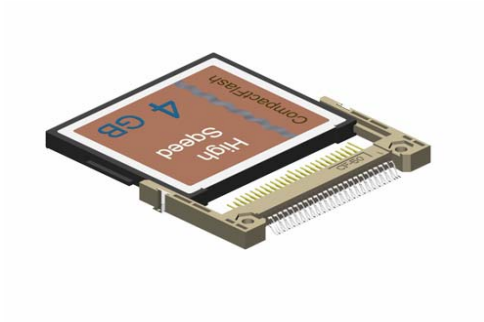

Compact Flash Connectors

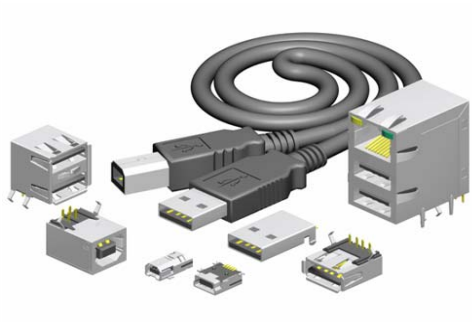

USB & IEEE 1394 Connectors

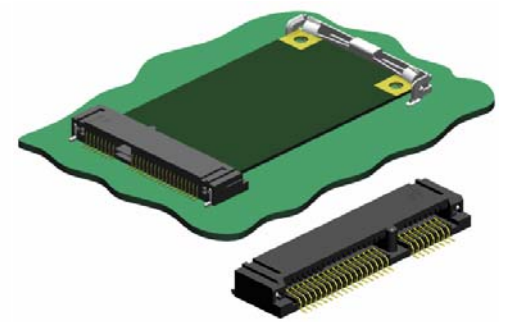

Mini PCI Express Connectors

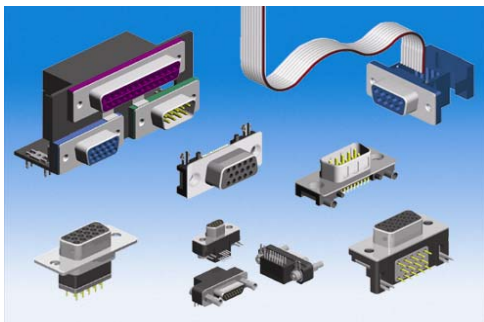

D-Sub Connectors

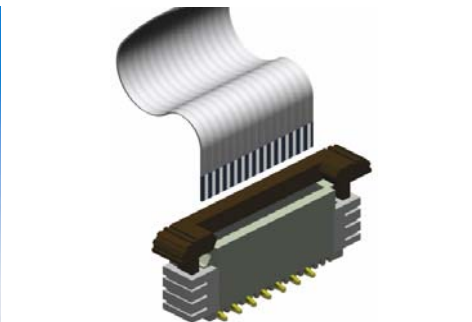

Flex Cable Connectors



HDMI Connectors



Probe Pin & Probe Pin Connectors

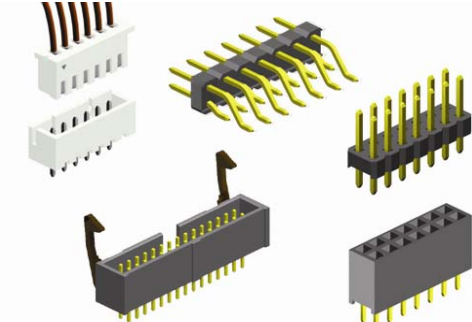

PCB Connectors

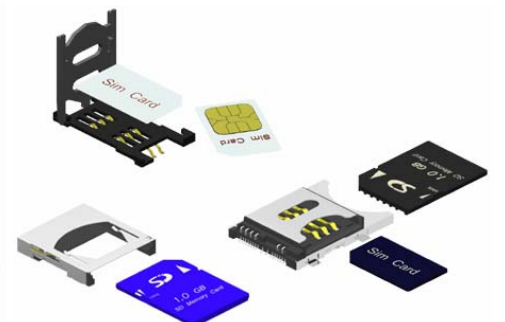

Multi Media Card Connectors

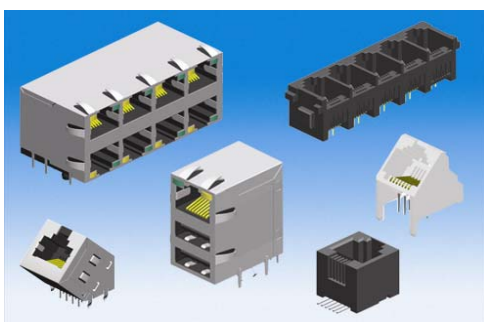

Modular Plugs & Jacks

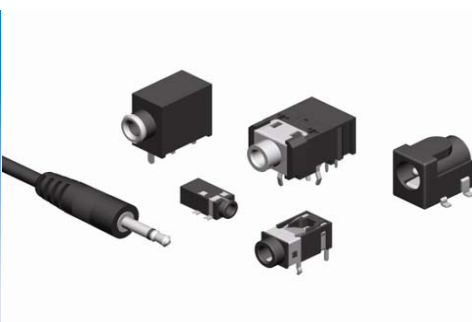

Phono - & DC - Power Connectors



RF - Connectors

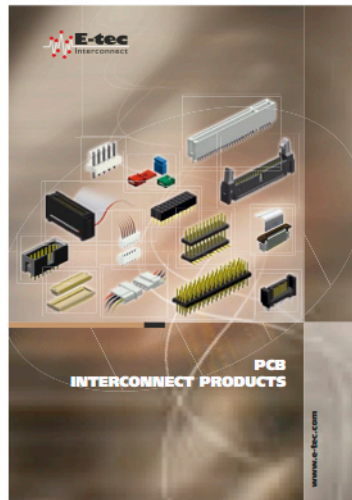
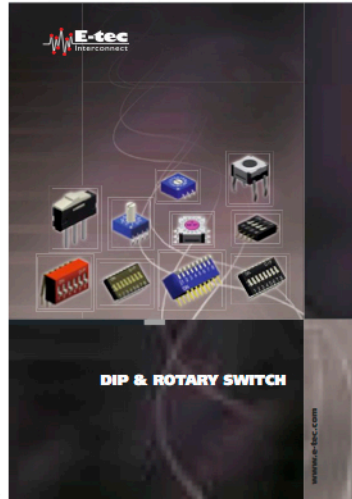

International Sales Headquarters

Switzerland E-tec Interconnect Ltd.
Schweiz Zone Industrielle C
Suisse CH-1072 Forel (Lavaux)
Phone: +41/21/7810810
Fax: +41/21/7810811
e-mail: info@e-tec.com
www.e-tec.com

Related Sales Headquarters

Deutschland EMC electro mechanical components
Germany Vertriebs GmbH
Allemanne PF. 1160
D-65501 Idstein
Phone: +49/61 26/9395-0
Fax: +49/61 26/9395-72
e-mail: info@emc-connectors.com
www.emc-connectors.com

France Silfox SA
Frankreich PA des Petits Carreaux
2 bis avenue des Coquelicots
F-94385 BONNEUIL
SUR MARNE CEDEX
Phone: +33/1/49560468
Fax: +33/1/49560287
e-mail: info@silfox.fr
www.silfox.fr

England E-tec Interconnect (UK) Ltd.
Angleterre Units A5 & A6 Decimus Park
Kingstanding Way
Tunbridge Wells
Kent TN2 3GP
Phone: +44/1892/530260
Fax: +44/1892/515560
e-mail: info@e-tec.co.uk
www.e-tec.co.uk

Factories

Switzerland E-tec AG
Schweiz Friedhofstrasse 1
Suisse CH-2543 Lengnau b. Biel
Phone: +41/32/654 15 50
Fax: +41/32/652 26 93
e-mail: info-ch@e-tec.com
www.e-tec.com

Taiwan E-tec Interconnect Asia Ltd.
10F-2, No. 379, Jhongshan Road
SANCHONG Dist. New Taipei City
Taiwan R.O.C.
Phone: +886 / 2 / 29 99 - 27 26
Fax: +886 / 2 / 29 99 - 52 55
e-mail: info@e-tec-asia.com.tw
www.e-tec-asia.com.tw

YOUR AUTHORISED DISTRIBUTOR
IHR VERTRAGS-DISTRIBUTOR
VOTRE DISTRIBUTEUR OFFICIEL